

The image features a background of solar panels installed on a roof, viewed from a low angle looking up. The sky is a mix of blue, purple, and orange, suggesting a sunset or sunrise. The solar panels are dark blue with a grid of silver lines. The 'stem' logo is in the top left corner.

# stem

## **Stem General Installation Guide for Data Acquisition Systems**

**December 2024**

# Stem General Installation Guide for Data Acquisition Systems

© 2024 by Stem. All rights reserved.

This document is the confidential and proprietary information of Stem. No part of this document may be photocopied, reproduced, stored in a retrieval system, or transmitted in any form or by any means whether electronic, mechanical, or otherwise without prior written permission.

Stem reserves the right to change details in this publication without notice.

PowerTrack, PowerLobby, PowerDesigner, PowerInvoice, PowerLogger, and PowerManager are the trademarks of Stem.

Other product names and/or organization names mentioned may be trademarks and/or registered trademarks of their respective companies.

Revision History			
Revision	Date	Author	Comments
14	October 2021	Engineering	Updated to reflect new systems
15	March 2023	Engineering	Removed non-installation information Updated charts and photos
16	December 2024	Engineering	Updated photos Changed Albedo to Reflected Horizontal Irradiance (RHI)

## Limitation of Liability

Stem reserves the right to make changes to its products and/or their specifications without notice. Obtain the latest version of the device specifications to ensure the most current information is available to the customer.

Stem assumes no liability for applications assistance, customer's system design, or infringement of patents or copyrights of third parties by/or arising from the use of Stem devices.

STEM SHALL NOT BE LIABLE FOR CONSEQUENTIAL DAMAGES SUSTAINED IN CONNECTION WITH STEM PRODUCTS, EXCEPT TO THE EXTENT PROHIBITED BY APPLICABLE LAW. FURTHERMORE, STEM NEITHER ALLOWS NOR AUTHORIZES ANY OTHER PERSON TO ASSUME FOR IT ANY SUCH OBLIGATION OR LIABILITY.

Although the information contained in this document is believed to be accurate, Stem assumes no responsibility for any errors which may exist in this publication.

## Installation Personnel

Installation and maintenance of the communications enclosure should only be performed by qualified, competent personnel who have appropriate training and experience with high voltage and current devices. The communications enclosure must be installed in accordance with all Local and National Electrical Safety Codes.

## Warning

Failure to observe the following may result in severe injury or death:

- Keep these instructions.
- There are no user-serviceable parts inside. Refer service to an authorized service person.
- During normal operation of this device, hazardous voltages are present on the input terminals of the devices and throughout the connected power lines. With their primary circuit energized, current transformers (CTs) may generate a high voltage when their secondary windings are open. Follow standard safety precautions while performing any installation or service work (i.e., remove line / PT fuses, short CT secondaries, disconnect power whenever adjusting terminations).
- This product must be used in accordance with the instructions in this manual. Otherwise, the product may not perform as expected and can cause hazards to the user.

## Danger

Line voltages up to 600 VRMS are present on the input terminals of the device and throughout the connected line circuits during normal operation. These voltages may cause severe injury or death. Installation and servicing should be performed only by qualified, properly trained personnel.

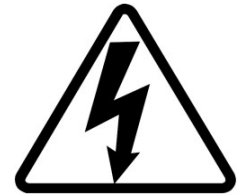

## CSA - C22 Statement

This product meets the requirements of Can/CSA-C22.2 no. 61010-1, second edition, including Amendment 1, or a later version of the same standard incorporating the same level of testing requirements.

## FCC Statement

This device is classified as a Class A digital device.

This device complies with Part 15 of the FCC Rules. Operation is subject to the following two conditions: (1) this device may not cause harmful interference, and (2) this device must accept any interference received, including interference that may cause undesired operations.

## Contents

1	General .....	6
1.1	Electrical Wiring.....	6
1.2	Documentation .....	6
1.3	Disclosure.....	6
1.4	Warranty .....	6
2	Product Overview.....	6
3	Installation Procedure .....	7
3.1	Recommended Tools and Materials.....	8

3.2 Wiring Sequence .....	8
3.3 Stem Site Documentation Package .....	8
3.3.1 Single Line Diagram .....	8
3.3.2 Communications Table.....	10
3.4 Enclosure Mounting .....	11
3.4.1 Location .....	11
3.4.2 Distance Limitations .....	11
3.4.3 Enclosure Dimensions .....	11
3.4.4 Mounting Brackets .....	14
3.4.5 Power .....	14
3.4.6 Enclosure Penetrations .....	14
3.5 Grounding Considerations .....	15
4 Installation Connections.....	16
4.1 Primary Power Connections.....	16
4.2 Field Connections – RS-485 and 24 VDC Device Power .....	16
4.2.1 Stem 24VDC and RS-485 Surge Suppressor – OVPR2P1 .....	16
4.2.2 24 VDC Power to External Devices.....	17
4.2.3 RS-485 Data Connections .....	19
4.2.4 Device Programming: Setting a Unique Modbus Address .....	20
4.3 Meter .....	21
4.3.1 Production, Consumption, Grid, or Battery Metering Locations .....	21
4.3.2 Installing Current Transformers (CTs).....	22
4.3.3 Extending CT Leads to the Meter.....	24
4.3.4 Fusing of Revenue Grade Meter Voltage Taps .....	25
4.3.5 Identifying Swapped Phases .....	25
4.3.6 CT Shorting (5A CTs only) .....	25
4.3.7 Typical Meter Installation .....	26
4.4 Cellular Modem and Antenna Installation .....	27
4.5 Stem Weather Stations .....	27
4.5.1 Installation Recommendations.....	27
4.5.1.1 Pyranometer Mounting .....	28
4.5.1.2 Pyranometer Orientation .....	29
4.6 Integrated Weather Station (IWS).....	31
4.7 Remote Enclosure Mounting and Connecting .....	32
4.8 Standard Weather Station Sensor Installation and Connections.....	33
4.8.1 Analog Sensors .....	34

4.8.2 Digital Sensors .....	40
4.8.3 Stem Weather Station Junction Boxes .....	48
4.9 Uninterruptible Power Supply (UPS) Installation .....	49
4.9.1 UPS Wiring .....	49
4.9.2 Make / Check Connections.....	50
4.9.3 Energize System.....	51
4.10 Transformer Dry Contact Monitoring.....	51
4.11 KYZ Pulse Meter .....	52
5 Troubleshooting .....	54
5.1 Power Connections .....	54
5.2 PowerLogger 1000 .....	54
5.2.1 Screen Calibration .....	54
5.2.2 No PowerTrack Connection.....	54
5.2.3 RS-485 Devices Not Responding in PowerTrack.....	55
5.3 Data Logger Does Not Communicate with an End Device .....	55
5.4 RS-485 Modbus Troubleshooting.....	56
5.5 Meter .....	56
5.5.1 Voltage Readings Not as Expected.....	56
5.5.2 Current Readings not as Expected.....	57
5.5.3 Identifying Swapped CT Phases .....	57
5.6 Internet Access.....	57
5.7 Stem Weather Station .....	57
5.7.1 Weather Station Communication Issues .....	58
5.7.2 Weather Station Sensors .....	58
5.8 UPS .....	61

# 1 General

## 1.1 Electrical Wiring

Because of possible electrical shock or fire hazards, the connection of this equipment should only be made by qualified personnel in compliance with all local applicable electrical codes and standards.

## 1.2 Documentation

This manual is meant to cover the installation and troubleshooting of standard installations. Stem supports many configurations and specific installations.

## 1.3 Disclosure

This publication contains information proprietary to Stem. No part of this publication may be reproduced in any form without prior written consent from Stem.

## 1.4 Warranty

The Stem communications enclosure is warranted to the original purchaser against defective material and workmanship. During the warranty period, Stem will repair or replace, at its option, all defective equipment that is returned freight prepaid. There will be no charge for repair provided there is no evidence that the equipment has been mishandled or abused. If the equipment is found to be in proper working order, a service fee will be charged. The complete terms and conditions of the warranty are located at [www.Stem.com](http://www.Stem.com).

# 2 Product Overview

The Stem communications enclosure interfaces RS-485 and TCP/IP devices with the Stem database via an internet-accessible Ethernet connection. The Stem communications enclosure optionally includes a weather station digitizer, an Ethernet switch, and revenue grade power meter(s).

All data loggers come equipped with at least one Modbus RTU port that is compatible with half duplex (2wire) RS-485 communications. These components are housed in a powder-coated steel enclosure intended for mounting indoors or outdoors, close to the electrical equipment being monitored.

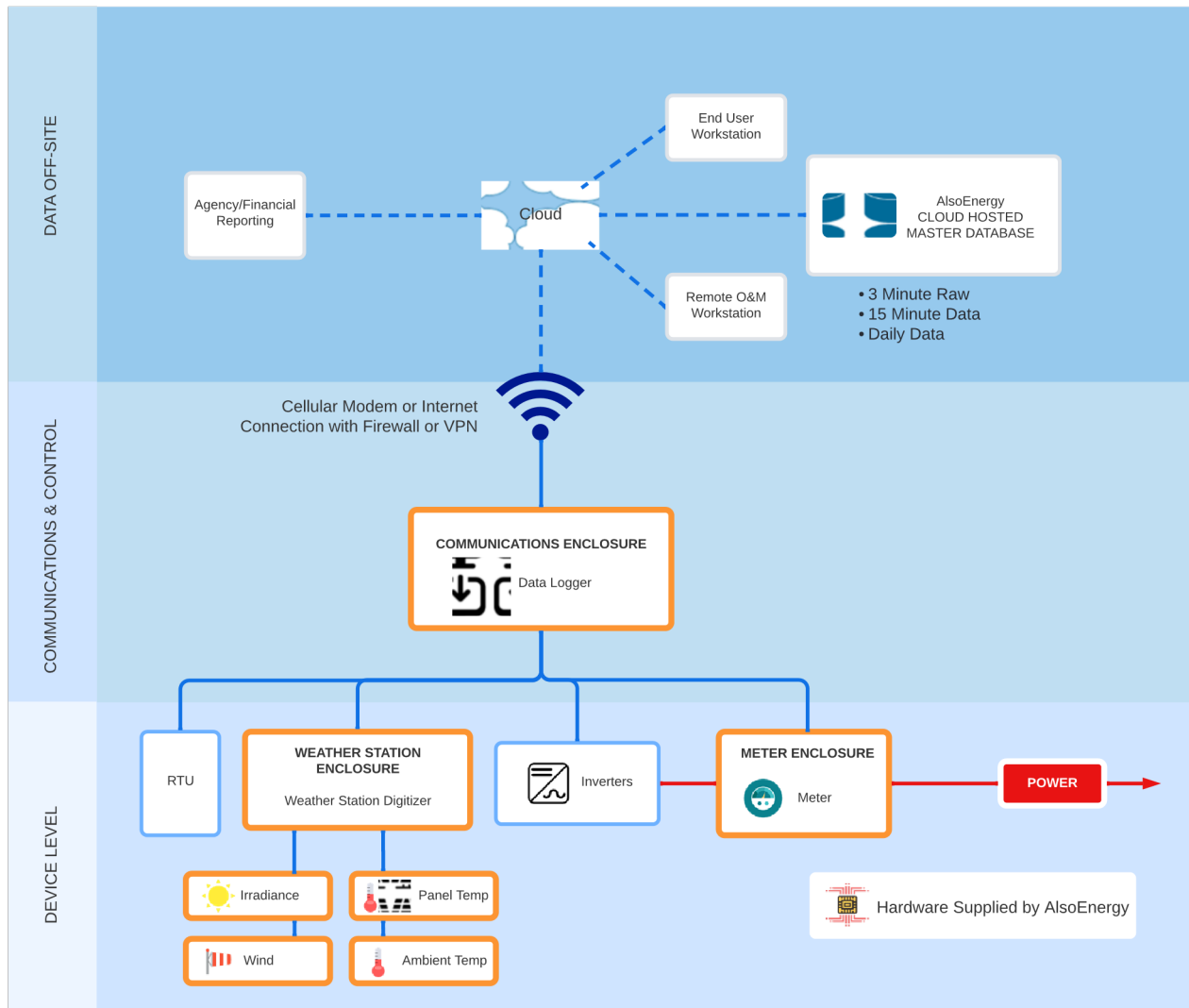

Figure 1: Basic Monitoring System Diagram

### 3 Installation Procedure

**Warning**

The Stem enclosure contains sensitive electronics and high voltages. The enclosure needs to remain weather-tight for its entire expected lifetime. Proper installation is the best defense against future service calls and expenses.

## 3.1 Recommended Tools and Materials

- Drill and Bit Set
- Knockout Set
- Wire Stripper/Cutter
- Small Flathead Screwdriver
- Large Flathead Screwdriver
- AC/DC Multimeter
- RJ45 Connectors and Crimp Tool
- Dielectric Grease
- Network Cable Tester
- Mounting Hardware to Mount Enclosures, Sensors, and Radios
- Outdoor-rated Shielded STP Cat5e or Better Cable
- Conduit and Rain-Tight Connectors
- Loctite® Epoxy Plastic Bonder and Kapton (polyimide) Tape for Panel Temp Sensor

## 3.2 Wiring Sequence

The following sections provide detailed wiring instructions and diagrams. For the devices that apply, the recommended order of wiring is:

1. Power for the communications enclosure: Ground, AC Power.
2. Internet Connection (wired, fiber, Ethernet radios).
3. External Modbus devices, i.e., inverters, external weather stations, and external meters.
4. Weather station sensors for an internal weather station.
5. Voltage and CTs for revenue grade energy meters (Consumption and/or Production).
6. Weather station sensors for the external remote weather station.

## 3.3 Stem Site Documentation Package

Each monitoring package comes with a corresponding Stem document package. This package provides all site-specific information necessary to install and commission the DAS. The site documentation package may contain all or some of the typical sheet types.

### 3.3.1 Single Line Diagram

The Single Line Diagram (SLD) sheets are the primary guide to field installation and commissioning of the system. Refer to these sheets to determine correct cable landings for all field connections. The complete communication wiring diagram of components within the Stem DAS assembly is also shown as reference for commissioning and troubleshooting. Reference [Figure 2](#) for the following:

1. **Internal Communication Wiring:** These connections will be pre-wired by Stem and are shown for reference only.
2. **Device:** Device ID is shown in blue text, additional references to this device will reference this ID.
3. **Field Wiring Bus:** ID references the parent device and the bus number. For detailed information on field connections to device busses reference the relevant section of this manual for the device.

4. **Power Input:** One of the required field connections to the enclosure, this shows the bus label and corresponding voltage for all power inputs to the enclosure. If more than one input is required for an enclosure care must be taken to connect each according to the diagram. **Connecting inputs to incorrect voltages may result in damage to components, fire, injury, or death.**
5. **Location:** The ID and name of the Stem enclosure or location at the site.
6. **Weather Sensor:** Represented by sensor type symbol and device ID. Connect sensors exactly as shown.
7. **RS-485 and 24 VDC Field Termination and OVP:** Each OVP device has field landing terminals for 24VDC and up to two independent RS-485 busses. Make field connections to the appropriate RS485 channel as specified in the diagram in the site documentation package.
8. **Field Installed RS-485 Daisy Chain:** Connect device RS-485 daisy chains as shown in the diagram, always following RS-485 wiring best practices outlined in the [RS-485 Data Connections](#) section to avoid communication failures.
9. **Field Installed Power and RS-485 for Remote Devices:** If power and communication wiring is required for an external device then both will be shown and should be connected as depicted in the diagram.
10. **Cable Key:** Cable types are distinguished by both color and pattern, refer to the key to determine the wire or cable needed for each connection.

### Best Practice: Wire Labeling

All external electrical and communications wires should be labeled, e.g. "To Pad 1 Enclosure," "To Meter 3," etc. A colored tape can be used to designate CT and VT phases. Having labeled wires will save time during commissioning and troubleshooting.

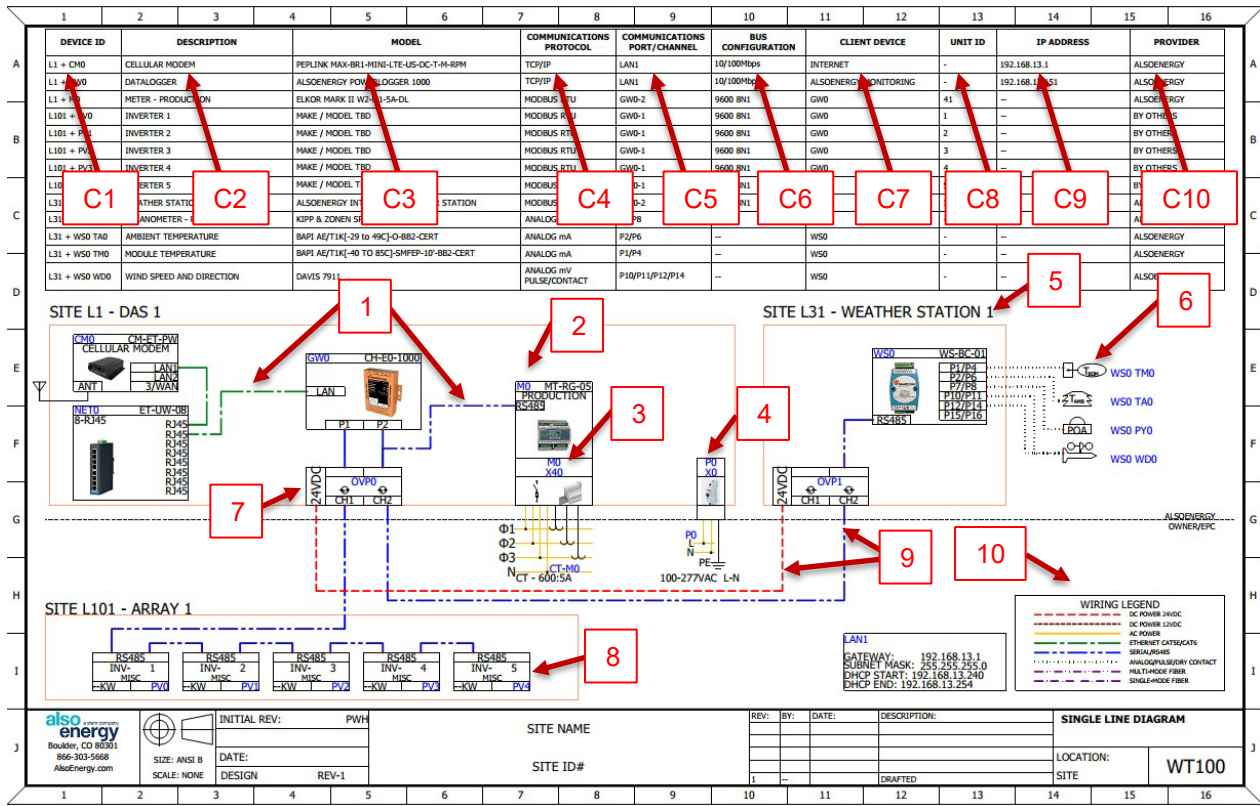

Figure 2: Single Line Diagram and Communications Table

### 3.3.2 Communications Table

The communications table is the primary reference for device communication settings and includes all information needed to establish a connection for data acquisition of intelligent devices. Only devices that are monitored or require a communication configuration are included in this table. Refer to [Figure 2](#) for the following:

- C1. **Device ID:** References both the location ID and ID of the communicating device.
- C2. **Description:** The name of the device at the site, Production Meter, Inverter 4, etc.
- C3. **Model:** The manufacturer part number or reference for the device.
- C4. **Communication Protocol:** The communication protocol for data acquisition.
- C5. **Communication Port Channel:** The serial port of the client device that the device will connect to or the local area network (LAN1, LAN2, etc.) that will be used for TCP/IP communication. Serial ports will reference the serial client and the index of the port. For example, GW0-3 references the third serial port on the client device GW0.
- C6. **Bus Configuration:** RS-485 Modbus RTU protocol will use a configuration of 8 data bits, no parity, and 1 stop bit with a baud rate of 9600 (9600 8N1) unless otherwise specified. Ethernet shall be 10/100Mbps unless otherwise specified.
- C7. **Client Device:** The device(s) that will be receiving data. Multiple clients may be listed if data is received by multiple clients or passes through protocol converters.

- C8. **Unit ID:** This is the Modbus address or Unit ID of the device. Unit IDs must be unique per serial bus but may be duplicated if devices are connected to isolated buses.
- C9. **IP Address:** IP addresses must be unique for each device that is connected to the same local area network. In some cases, the TCP port may be specified, the default port for Modbus TCP communication is 502 unless otherwise specified. If a protocol converter or data concentrator is used to pass the device data to the client, the IP address of the converter/concentrator will be listed in addition to the unit ID.
- C10. **Provider:** Hardware provided by Stem or others.

## 3.4 Enclosure Mounting

### 3.4.1 Location

Mount to an indoor or outdoor wall following the instructions in this section.

- The unit should be placed in a secure location, away from any potential tampering
- Mount to an indoor or outdoor wall using four 2-1/4" screws through the holes in the mounting flanges
- Allow space beneath the enclosure for conduit runs for all input and output wires
- Allow space in front of, and adjacent to, the unit to allow the front door to open fully

### 3.4.2 Distance Limitations

- Maximum 328 ft (100 m) from the data logger to an internet connected network port
- No further than 6 ft (2 m) from earth ground
- Maximum 4,000 ft (1200 m) between the communications enclosure and last RS-485 device
- Maximum 50 ft (15 m) to any RS-232 device
- Maximum 6500 ft (2 km) per multimode fiber run (100 Mbit/s)
- Maximum 24.8 miles (40 km) per single-mode fiber run

### 3.4.3 Enclosure Dimensions

It's important to keep the dimensions of the enclosure in mind while planning out how and where to mount it. Use [Figure 3](#) in conjunction with [Table 1](#) and [Table 2](#) to determine the area needed for mounting, as well as preparing safe lifting practices according to the weight of the enclosure.

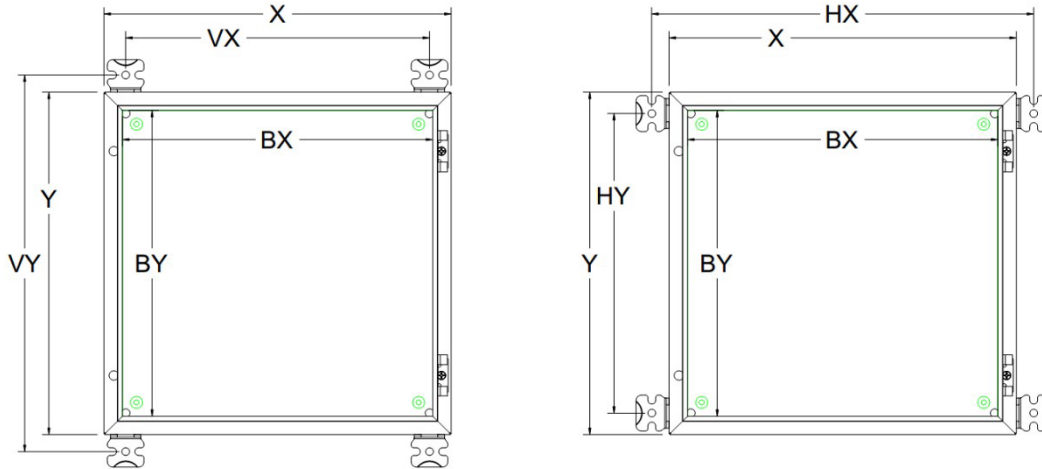

Figure 3: Enclosure Dimensions Diagram

Enclosure Dimensions (mm (in.))					
Part No.	External Dimensions			Backplate	
Item	X	Y	Z	BX	BY
E4-ST-NL	400 (15.75")	400 (15.75")	200 (7.9")	350 (13.8")	350 (13.8")
E4-LG-NL	400 (15.75")	600 (23.6")	200 (7.9")	350 (13.8")	550 (21.7")
E4-XL-NL E4-XLV-NL	800 (31.5")	800 (31.5")	300 (11.8")	750 (29.5")	750 (29.5")
E4-664-PS E4-664-PSV	600 (23.6")	600 (23.6")	397 (15.6")	550 (21.7")	550 (21.7")
PMCS-GX	636 (25.0")	847 (33.4")	300 (11.8")	550 (21.7")	750 (29.5")
PMCS-GL	436 (17.2")	647 (25.5")	250 (9.8")	350 (13.8")	50 (21.7")

Table 1: Enclosure Dimensions

Bracket Orientation Spacing (mm (in.)) and Enclosure Weights (kg (lb.))					
Part No.	Vertical Bracket Orientation Spacing		Horizontal Bracket Orientation Spacing		Approximate Weight
	VX	VY	HX	HY	
Item					-
E4-ST-NL	357 (14.1")	440 (17.3")	440 (17.3")	357 (14.1")	11-16kg (25-35lb.)
E4-LG-NL	357 (14.1")	640 (25.2")	440 (17.3")	557 (21.9")	18-23kg (40-50lb.)
E4-XL-NL E4-XLV-NL	757 (29.8")	840 (33.1")	840 (33.1")	757 (29.8")	43-52kg (95-115lb.)
E4-664-PS E4-664-PSV	557 (21.9")	640 (25.2")	640 (25.2")	557 (21.9")	43-52kg (95-115lb.)
PMCS-GX	530 (20.9")	889 (35.0")	664 (29.7")	755 (29.7")	43-52kg (95-115lb.)
PMCS-GL	330 (13.0")	689 (27.1")	464 (18.3")	555 (21.9")	27-32kg (60-70lb.)

Table 2: Bracket Orientation Spacing and Enclosure Weights

The weights provided in [Table 2](#) are approximate and for reference only. Actual weight will vary depending on the type and quantity of hardware within the enclosure. Weight estimates do not include batteries – add 25 kg (56 lb) per 38 Ah battery pair and 9 kg (20 lb) per 12 Ah battery.

### 3.4.4 Mounting Brackets

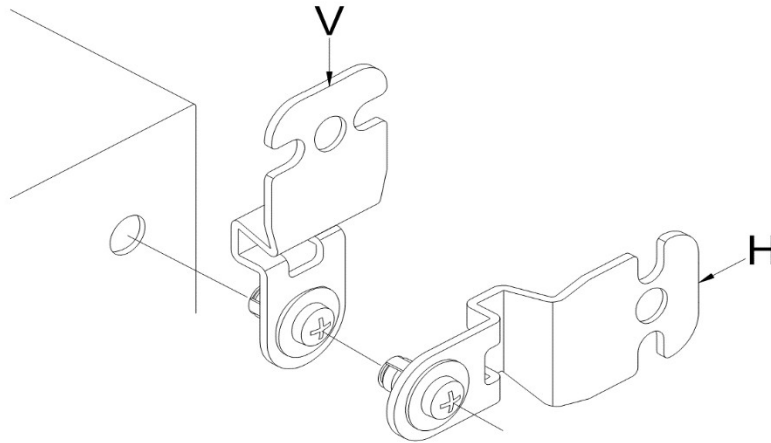

Figure 4: Mounting Brackets Shown in Vertical and Horizontal Positions

Enclosure mounting screws and sealing gaskets are included with the mounting brackets. Use M8 bolts to mount to the racking structure.

Orientation of mounting brackets is left to the discretion of the installer.

Mounting screws for fiberglass reinforced polycarbonate enclosures do not penetrate the enclosure and do not include a gasket as it is not necessary. Mounting bracket appearance may vary by model.

### 3.4.5 Power

- The standard power supply in the Stem Communication Box requires 120 – 277 VAC, 50/60 Hz, and is auto-ranging. Typical enclosure loads are less than 2 A at 120 VAC. Other power supplies such as 480 VAC L-L power supply for 3-wire delta 480 V systems are available.
- The monitoring system should be protected by a main circuit breaker rated up to 20 A.
- Allow access to a proper earth ground.

### 3.4.6 Enclosure Penetrations

- All conduits and wires must enter from the **bottom** of the enclosure. Do not penetrate the top or sides of the enclosure.
- All entry points must be sealed using weatherproof connectors.

- The enclosure contains electronics that are sensitive to water damage. Ambient humidity, condensation, and water infiltration are common causes of damage to circuitry. Avoid costly repairs and losses caused by water damage by using adequate weatherproofing techniques and managing humidity.
- All penetrations to the enclosure should be liquid-tight to maintain the longevity of the electronics. All conduit connectors must be outdoor rated. ○ Stem supplies desiccant packets within all enclosures to prevent excessive humidity and prolong the life of the sensitive electrical devices.
  - **Remove the desiccant packet from the plastic wrapper it's shipped in.**
  - **Please leave the desiccant packets inside the enclosure after installation is complete.**
  - **The supplied Humidity Indicator card should be placed in a visible location in the enclosure.**
  - Replace the desiccant packet when the Humidity Indicator Card shows 40% humidity or higher.
- **Warranty will be voided if there are entry points on the top or sides of the enclosure.**



Figure 5: Desiccant Pack in Plastic Wrapper

## 3.5 Grounding Considerations

Ground the enclosure according to NEC requirements and local regulations.

## 4 Installation Connections

Connections may be required for power, data, CTs, voltage reference, digital I/O, and/or analog sensors. Refer to the Single Line Diagram for site-specific detail regarding terminations.

### 4.1 Primary Power Connections

All input connections are made to DIN Rail terminal blocks as shown in [Figure 6](#). Connect 12-14 AWG wire to the terminal blocks pre-labeled with the proper power supply connection with the line, neutral, and ground wires. If multiple power inputs will be connected to an enclosure, care must be taken to connect each input to the correct voltage.

**Connecting the incorrect voltage may lead to equipment failure, fire, injury, or death.**

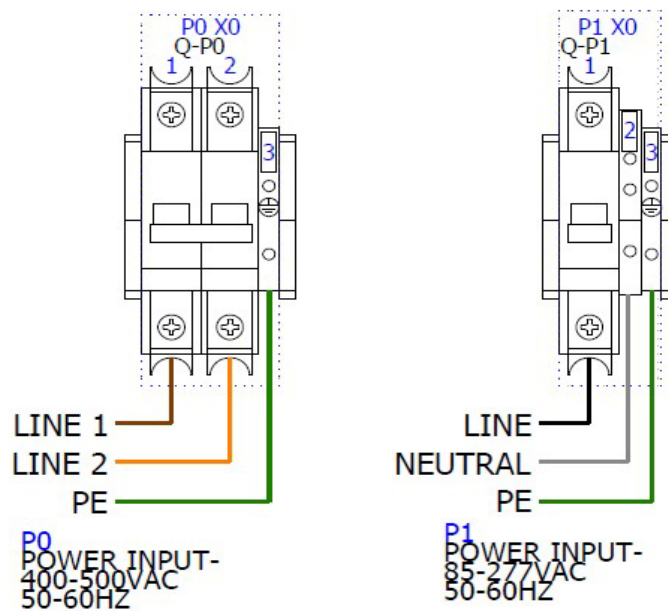

Figure 6: Typical Power Input 2-Pole L-L [Left], 1-Pole L-N [Right]

## 4.2 Field Connections – RS-485 and 24 VDC Device Power

### 4.2.1 Stem 24VDC and RS-485 Surge Suppressor – OVPR2P1

The OVP-R2P1 Surge Suppressor has field-wiring rated terminals for landing 24 VDC and two separate RS-485 inputs for connecting devices such as weather sensors or remote meter enclosures. Devices inside

the enclosure will be factory-wired by Stem to the **PROTECTED** side of the OVP-R2P1 device. **Field terminations must be landed at the UNPROTECTED terminals at the bottom of the OVP-R2P1.**

Landing field devices at the protected side of the surge suppressor will negate all protection and expose all devices to potential surges. Double wire landing is permitted with wire up to 16 AWG, no larger. At least one Shield/PE terminal on the device must be connected to a protective earth ground with 14 AWG or larger wire.

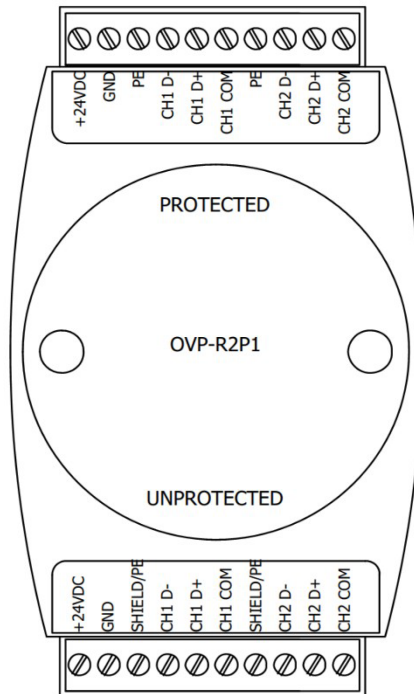

Figure 7: Stem OVP-R2P1 Surge Suppressor

## 4.2.2 24 VDC Power to External Devices

24 VDC power output may be provided for external devices such as weather sensors or meters. For enclosures containing an over-voltage protection device, external 24 VDC power should be connected to the unprotected 24 VDC port of the OVP device.

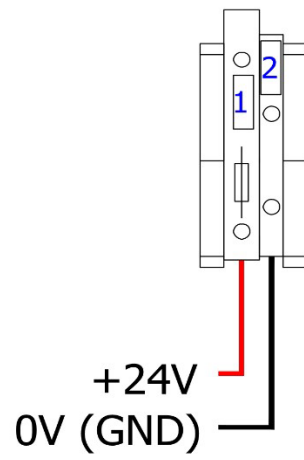

Figure 8: 24 VDC Fused Output without OVP

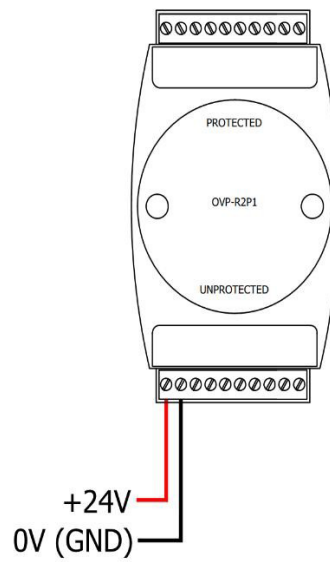

Figure 9: 24 VDC Output with OVP

### 4.2.3 RS-485 Data Connections

Connect the external devices (inverters, meters, remote weather stations) to the correct data channel (CH1 or CH2, see single-line diagram) of the DIN-mounted OVP, wired directly to the Modbus client. Be sure to wire the devices according to the single-line diagram supplied by Stem with the shipment. Connect the Modbus devices using Belden 3106A or equivalent shielded twisted pair RS-485 wire. Land the shield at only one end of the cable run.

If multiple RS-485 devices are to be connected on a bus, RS-485 best practices must be followed.

- Daisy Chain Configuration: Avoid star or hub wiring. **Each device on the chain must connect to no more than two cables: one going to the previous device in the chain, one going to the next.**

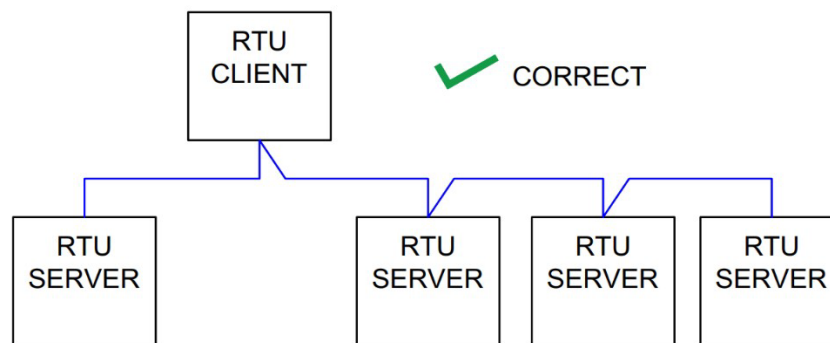

Figure 10: Example of Correct Daisy Chain Configuration

- Limited Device Quantity: Stem recommends limiting RS-485 daisy chains to no more than 20 devices on a single RS-485 bus.
- Avoid connecting devices using different baud rates or protocols together on an RS-485 bus.
- Data +/- may be labeled as data A/B on some devices. However, the polarity of “A” and “B” is not standardized. Always refer to manufacturer documents to determine proper polarity, then wire according to positive/negative rather than A/B. Devices will not communicate if polarity is reversed.

- Junction boxes may be necessary to daisy chain devices such as weather sensors with a factory provided cable rather than screw terminals. Use the Stem junction box (part number WSJB-01) or any suitable outdoor enclosure for junctions. Maintain a maximum of five sensors per junction box.
- Do not extend cable from junction box to sensor. Shorter cables may be necessary for daisy chains with multiple sensors. The RS-485 trunk between the RS-485 client and junction boxes may be extended following standard RS-485 best practices. Do not exceed 15m cable length for any stub off of a junction.
- Trim and insulate shield/drain at the final device in the chain. Do not land or ground at any point other than at the RTU client device.
- At each junction, splice the shield, do not land or ground it. Insulate the connection.
- Termination resistors are not typically used for 9600 Baud rate communication. If used, then ensure that only the final device in a daisy chain uses the termination resistor.

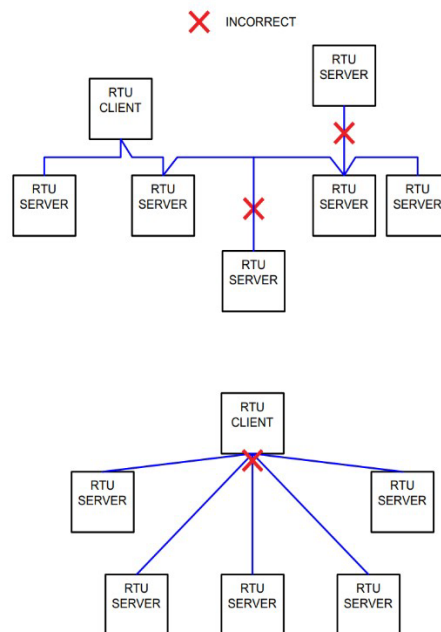

Figure 11: Examples of Incorrect Wiring - Avoid Star and Hub Configurations

## 4.2.4 Device Programming: Setting a Unique Modbus Address

All devices on each Modbus port need a unique address between 1 and 247. If two devices on the RS485 bus have the same address, neither device will successfully communicate. Stem -provided hardware will ship pre-configured to a unique address as specified in the site design package. Inverters and other field-connected devices must be connected and programmed by the installer. Refer to the supplied site-specific design package for addressing information and supplemental setup guides or installation manuals for connecting and programming information of devices as needed.

## 4.3 Meter

Install Current Transformers (CTs) and make all connections with all system AC and DC power turned **OFF**. Do not power on the system until you are sure all connections have been made and are secure.

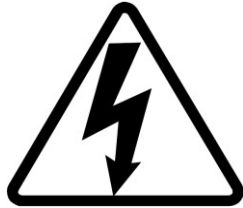

### **Danger**

This is a Class III Measurement Device. Line voltages up to 600 VRMS are present on the input terminals of the device and throughout the connected line circuits during normal operation. These voltages may cause severe injury or death. Installation and servicing should be performed only by qualified, properly trained personnel.

### 4.3.1 Production, Consumption, Grid, or Battery Metering Locations

The location of meter CTs and voltage taps is dependent on the meter type. Typical sites will use a production meter to monitor PV production with the option of additional consumption, grid, or utility meters. Energy sources may be a PV System, Utility Grid, Energy Storage System, Generator, or other generation systems. The positive direction of energy flow is always defined as energy being provided by these systems, as shown in [Figure 12](#).

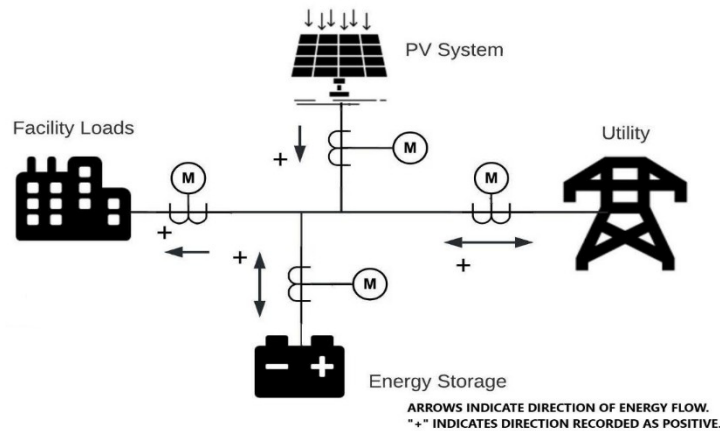

Figure 12: Metering Diagram

If a meter measures production from a generation source (PV system, wind generator, gas generator, etc.), it is labeled as a production meter in PowerTrack, and energy will only flow from the energy source.

If a meter only measures building/facility loads, it is labeled as a consumption, demand, or load meter in PowerTrack, and the energy will only flow from the power source(s) to be consumed by the facility.

If a meter is placed at the utility interconnect, then it is labeled as a grid or net meter in PowerTrack and energy can flow in either direction through the meter depending on the sum of site generation, storage, and building loads. A positive metered value indicates power flowing from the grid, while a negative value indicates power flowing to the grid (such as when PV generation is being sold back to the utility).

If a meter is placed on an AC coupled energy storage system, it is labeled as a battery or storage meter in PowerTrack and energy can flow in either direction through the meter depending on the energy storage

system charge controller. A positive metered value indicates power flowing from the energy storage system, while a negative value indicates recharging power flowing into the energy storage system.

### 4.3.2 Installing Current Transformers (CTs)

**CTs must all be identical for the system to operate.**

Stem enclosures and the hardware within are rated to 600 VAC nominal. If the metered circuit nominal voltage is greater than 600 VAC, then Medium Voltage CTs and revenue grade Potential Transformers must be used. **Stem does not provide MV hardware.**



Figure 13: Current Transformer Surrounding Wire

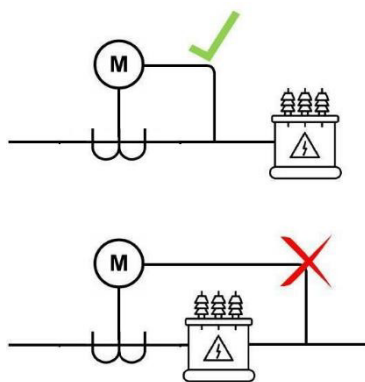

The location of CTs can vary depending on the site. Refer to the site documentation to determine the CT location. They should be placed in the same general location as voltage taps (they must be on the same side of the transformer) and in a location that captures all intended production (around all feeders associated with the metered circuit). Service panels and AC disconnect cabinets typically supply ample space and weather protection for CTs.

Figure 14: Proper Metering Near Transformer. Voltage Reference and Current Transformers Installed on the Same Side of the Transformer

Proper installation of Current Transformers (CTs) is crucial to the operation of any meter:

- Always observe the voltage and current relationship. In a three-phase system, it is imperative that the CTs match voltage from the same phase, i.e., the CT installed on phase A, must be wired to I11, I12 and the voltage from this phase must be wired to V1 and so on.
- It is highly recommended to label the CT wire leads with individual colors per phase before pulling the wire through the conduit. This will help prevent a mismatch of the installed phases.
- Observe the orientation of the CT on the wire. Each CT is labeled with a dot or marking “H1”. This side must face the energy generation source — some CTs show an arrow indicating the current direction. If the CTs are installed in reverse, the power measurements will have the opposite sign.

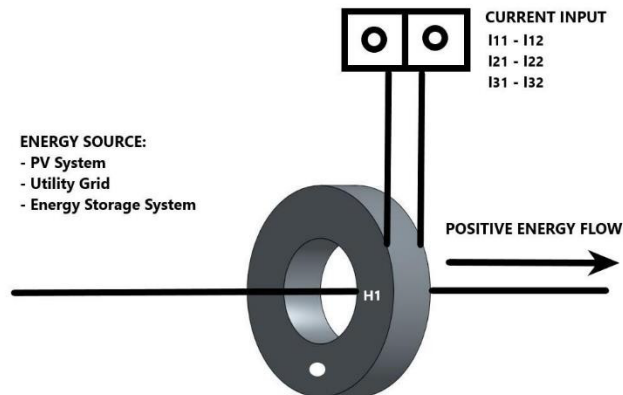

Figure 15: CTs Should Be Oriented with Dot Facing Source

- Observe the polarity of the CT wiring into the input terminals. X1 of each CT must be wired to the I11, I21, I31 terminals respectively. X1 and X2 will be labeled or color-coded by the CT manufacturer – see manufacturer’s data sheet for specific CT information.
- 5A output CTs should always be wired into a shorting block mechanism to provide a method of shorting the CTs for maintenance and safety purposes. Once properly installed, make sure the shorting bars are retracted or removed to supply proper signal to the meter.
- CTs must be mounted on rated insulated conductors.
- Field wiring terminals for meter voltage reference (VT or Vref) and CTs are listed in [Table 3](#). Carefully label wires entering the enclosure keeping voltage reference and CT wires separate. Landing a CT wire in a Vref terminal will typically result in a blown fuse requiring replacement before the system can function. **Connecting a voltage reference to a CT input will result in a dangerous short circuit that will cause permanent device damage and may result in fire, injury, or death.**

Meter Interface Terminals	
Terminal ID	Wire
1	Voltage Phase A (V1)
2	Voltage Phase B (V2)
3	Voltage Phase C (V3)
4	Neutral (V <sub>N</sub> )
5	CT X1 Phase A (I11)
6	CT X2 Phase A (I12)
7	CT X1 Phase B (I21)
8	CT X2 Phase B (I22)
9	CT X1 Phase C (I31)
10	CT X2 Phase C (I32)

Table 3: Meter Interface Terminals

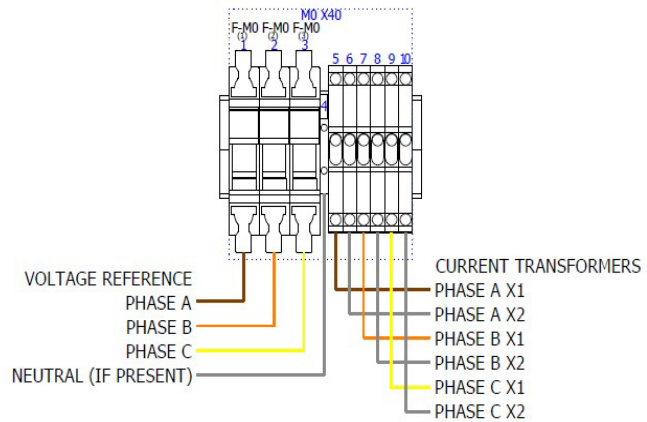

Figure 16: Field Wiring of Meter Interface Block

### 4.3.3 Extending CT Leads to the Meter

Stem recommends CT lead lengths be less than 20ft. If CT leads are extended without considering the burden, CT accuracy will be reduced.

The CT VA rating reflects the maximum allowable power on the CT secondary until the CT's rated accuracy is reduced below the listed rating. If CT leads need to be extended to the meter, use [Table 4](#) to determine the maximum recommended distance based on CT wire gauge. The length specifies the total distance between the meter and the CT, considering the total burden of the CT leads in both directions.

Wire AWG	Ohms/ft	CT VA Rating ( <i>Found on CT label or datasheet</i> )					
		2.5	7.5	10	15	25	35
20	0.01015	4.7 ft	14.5 ft	19.5 ft	29.3 ft	49.0 ft	68.7 ft
18	0.00639	7.4 ft	23.1 ft	30.9 ft	46.6 ft	77.9 ft	109.2 ft
16	0.00402	11.8 ft	36.7 ft	49.1 ft	74.0 ft	123.8 ft	173.5 ft
14	0.002525	18.8 ft	58.4 ft	78.2 ft	117.8 ft	197.0 ft	276.2 ft

12	0.001588	29.9 ft	92.9 ft	124.4 ft	187.3 ft	313.3 ft	439.2 ft
----	----------	---------	---------	----------	----------	----------	----------

Table 4: CT VA Rating and Maximum Lead Length by Wire Size

### 4.3.4 Fusing of Revenue Grade Meter Voltage Taps

The input voltage lines should include safety overcurrent protection and disconnect. Stem provides a 0.5 A Class CC fuse for all meter installations. Replacement fuses should be of similar type and rating.

### 4.3.5 Identifying Swapped Phases

A properly wired meter will record power factors near unity (PF between -0.9 and -1, or +0.9 and +1). If the metered power factor is outside of these ranges, check to ensure that voltage ref and CTs are matched phase-to-phase.

### 4.3.6 CT Shorting (5A CTs only)

To activate the CTs and activate the meter, it is **necessary** to loosen the retaining screws of the shorting pins and pull the orange tab down as seen in [Figure 17](#).

To service the CTs, it is **necessary** to remove the high current path from the working area. This may be accomplished by shorting the contacts as seen in [Figure 17](#).

**Note that this only serves to de-energize the wiring through the meter from the interface block. If the metered feeder is energized, then the CT leads are as well. Disconnecting an energized CT can lead to dangerous electric shock resulting in injury or death. Always de-energize the metered circuit using on-site Lockout-Tagout procedures before servicing CTs or CT leads.**

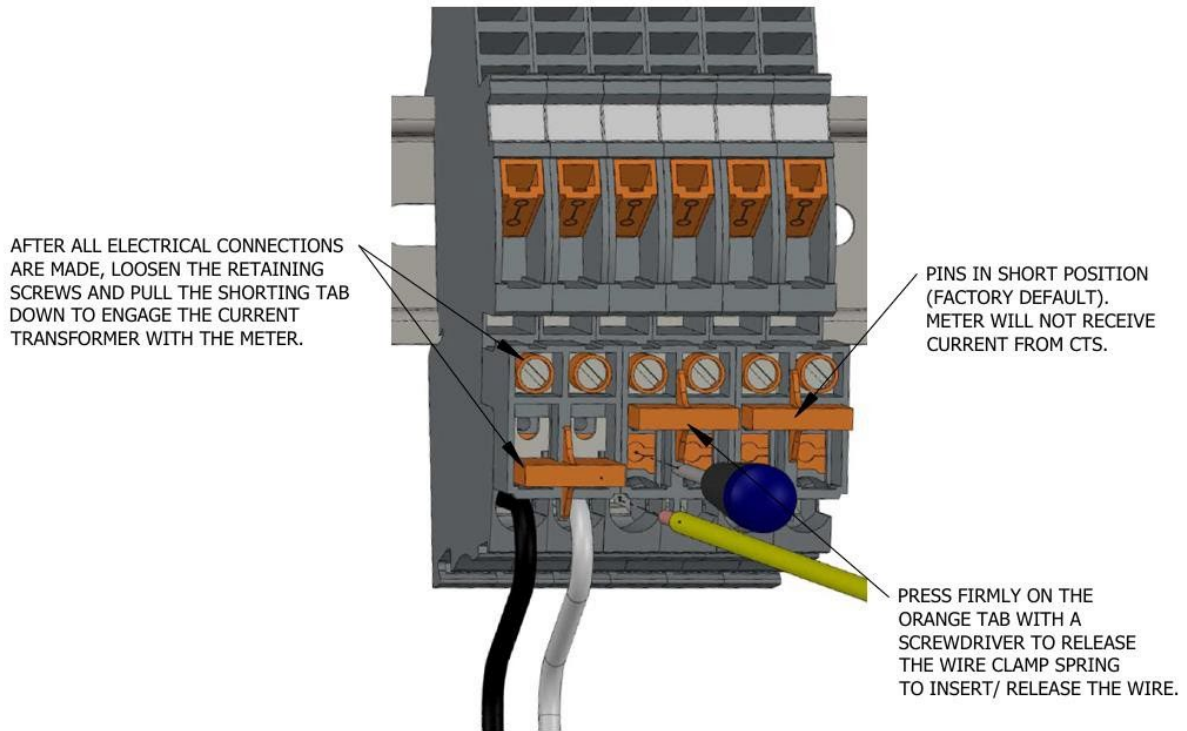

Figure 17: Meter Interface with Shorting Tabs

### 4.3.7 Typical Meter Installation

The wiring configurations for three-wire (delta) systems and four-wire (wye) systems are described in [Figure 18](#).

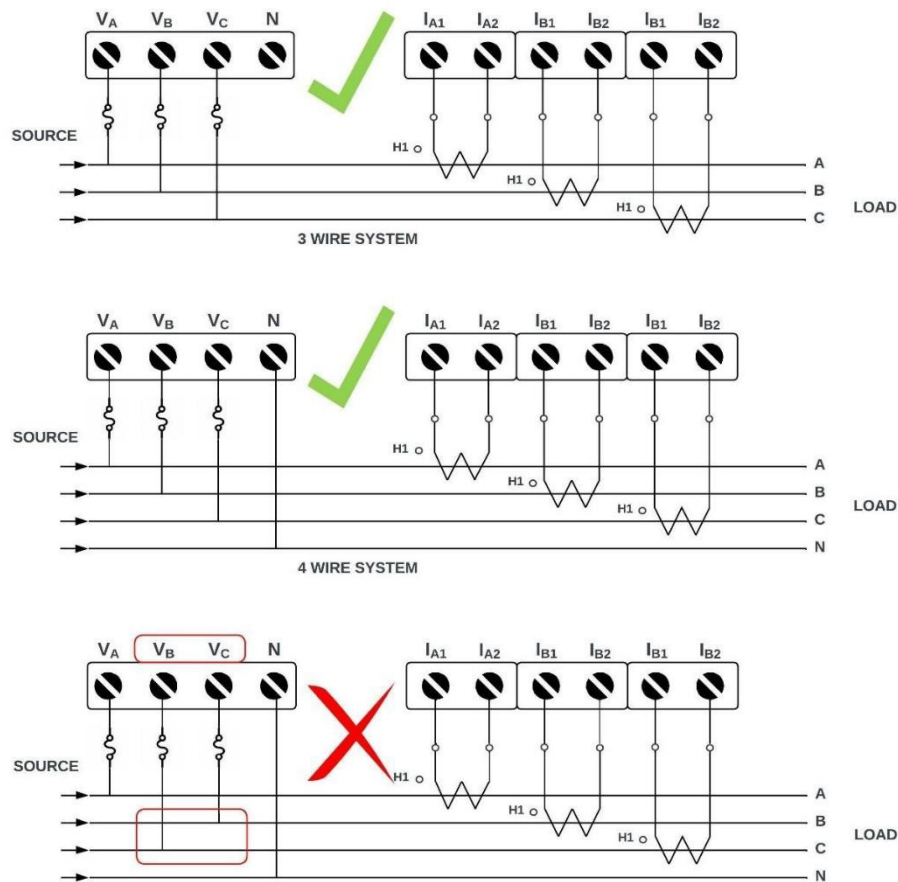

Figure 18: 3-Wire Delta and 4-Wire Wye Meter CT and Vref Wiring

## 4.4 Cellular Modem and Antenna Installation

Connect the antenna to the modem by routing the cable through the penetrations at the bottom of the enclosure. The magnetic antenna may be placed on top of the box or located anywhere within cable length for the best signal. Do not extend the antenna cable.

Use the signal bar indicators to determine the best location for antenna placement. Avoid placing the antenna inside steel enclosures. Large transformers or other sources of EMF radiation may interfere with signals. Locate the antenna further from these sources if signal strength is poor.

## 4.5 Stem Weather Stations

### 4.5.1 Installation Recommendations

- Kipp & Zonen SP Lite 2 pyranometers come equipped with 15 meters of cable. This cable may be extended up to 100 m with 24 AWG or larger wire and weatherproof gel-filled splices.

- Cable for other pyranometers is sold individually and may be purchased in a variety of lengths.
- Mount the ambient temperature sensor on a north-facing location that is never in direct sunlight.
- Install the module temperature sensor centered on a cell in the middle of a module on the underside. Choose a module that is not at the edge of the PV array.
- Back of Module sensors are self-adhesive. If using an additional adhesive, ensure that it is rated for up to 180° F. Stem recommends high-temperature epoxy. Kapton (polyimide) tape may be used to reinforce the back of module temperature probe adhesive.
- Outdoor shielded copper wire 24 AWG or larger can be used to extend temperature sensors a maximum of 100 m (328 ft). All splices must be made inside a weather-tight enclosure or with waterproof gel-filled splices.



For splicing sensors to extend cable length, Stem recommends using gel filled connectors. These will make a liquid-tight connection for the minimal voltage signals.

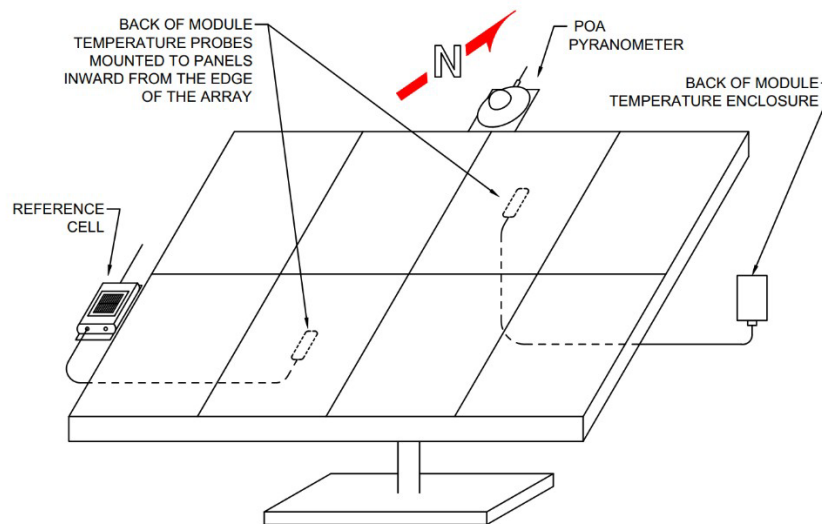

Figure 19: Examples of Sensors Mounting on a PV Array

### 4.5.1.1 Pyranometer Mounting

Use the mounting hardware included with the device to securely mount the sensor to the bracket using the mounting plate. It can be mounted tangentially or parallel on a pole. Ensure the mounting plate is perfectly parallel to the intended plane of measurement.



Figure 21: Mounting Plate Parallel to the Pole. Plane of Array (POA) Orientation Shown



Figure 20: Mounting Plate Perpendicular to the Pole. Global Horizontal Irradiance (GHI) Orientation Shown

Pre-drilled holes are provided to permit multiple options for sensor orientation. Select the appropriate mounting holes for the desired device position. Refer to [Figure 22](#) for mounting hole reference. For sensors equipped with a leveling screw, perform the final adjustment only after all other installation steps are complete.

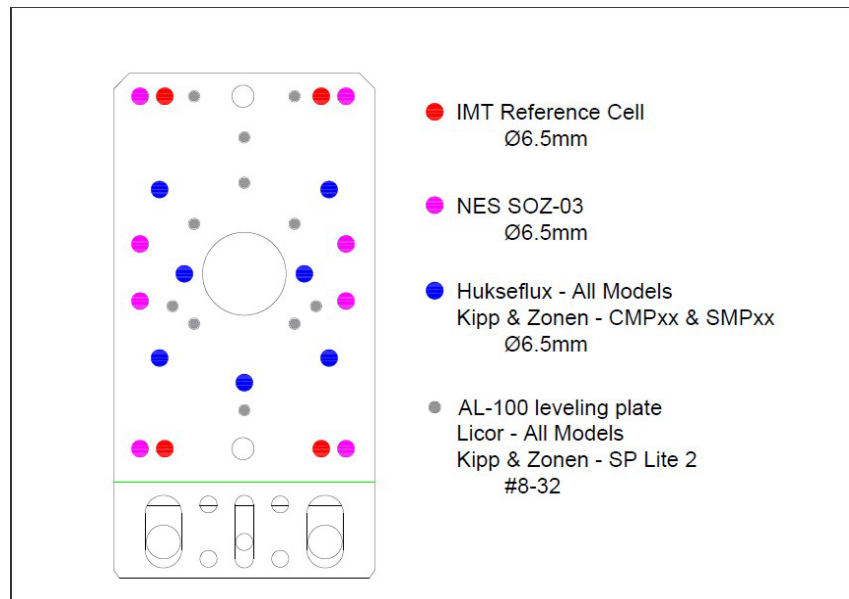

Figure 22: Mounting Holes for Select Pyranometers and Sensors

### 4.5.1.2 Pyranometer Orientation

Pyranometers may be oriented according to the desired angle of irradiance measurement.

#### Plane of Array (POA) and Backside Plane of Array (BPOA):

For systems with only one pyranometer, Stem recommends mounting the pyranometer on top of the north side of the array at the same angle as the panels. This orientation allows for the most accurate calculation of the predicted site power output. The pyranometer must not be shaded at any time of the day. BPOA pyranometers used in bifacial arrays will be mounted similar to a POA but facing downward at the same angle as the panels.

**Global Horizontal Irradiance (GHI) and Reflected Horizontal Irradiance (RHI, Formerly Albedo)**

A pyranometer mounted for GHI should be mounted above any surrounding obstructions to prevent shading. Mount GHI and RHI pyranometers to have a minimum distance of 10 times the height of nearby objects to reduce interference from reflections. Nearby light-colored walls or windows may drastically alter the measured irradiance. Use leveling screws to ensure that the pyranometer is completely level in all directions. RHI pyranometers should be mounted horizontally facing downward 1.5-2 m (5-6.5 ft) above the ground. The mounting ground below the RHI pyranometer should be representative of the ground surface of the PV array.

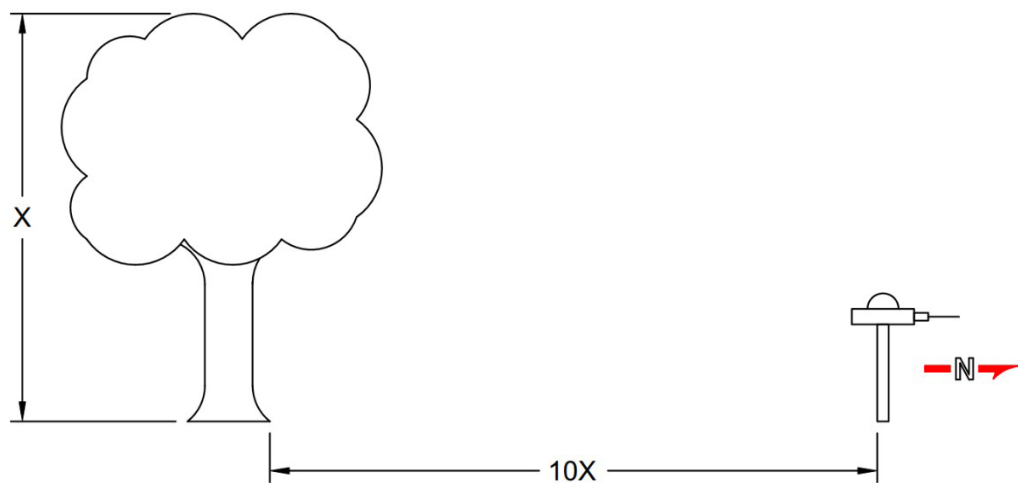

Figure 23: GHI Distance from Nearby Obstructions

## 4.6 Integrated Weather Station (IWS)

All sensor wires must enter the enclosure through the bottom with liquid-tight penetrations and strain relief. The weather station digitizer has a preconfigured address using the DIP switches.

Switches 1-6 set the Modbus Address of the digitizer. Switch 7, labeled “Learn” is set to the OFF (down) position during normal operation. After sensor installation, set this switch to ON for 1 minute, then return to the OFF position. Switch 8, “Term,” controls the termination resistor.

After power-up, the green light on the bottom will blink approximately once per second. The two yellow lights (TXD and RXD) will blink when data is being transmitted and received.



Figure 24: Stem Integrated Weather Station

## 4.7 Remote Enclosure Mounting and Connecting

If needed, the weather station card can be in a remote enclosure. Mount the remote enclosure following these distance guidelines:

- Less than 1000 ft from the communications enclosure
- At a convenient position inside the array for mounting of sensors
- Avoid extending sensor leads as much as possible. Consult specific sensor documentation for limits of extension.

The remote enclosure requires connections from the main communications enclosure. Both the weather station enclosure and the communication enclosure include an RS-485 and 24 VDC surge suppressor (OVP). Reference the Site SLD to determine the correct ports to connect the weather station. Connect similar terminals of the appropriate channels of the connected enclosures. Connect Data+ (D+) of the appropriate channel of the OVP at the communication enclosure to Data+ (D+) of the weather station enclosure. Repeat for Data- (D-), Data common (COM), 24 VDC, and GND. Land Shield/PE at one end of the cable only.

## 4.8 Standard Weather Station Sensor Installation and Connections

Stem has specific drivers for a wide selection of analog devices that may be connected through the Integrated Weather Station. Non-standard analog sensors with millivolt, milliamp, or dry contact signal may be supported with additional custom driver development for integration with PowerTrack.

Multiple sensors may be used to provide greater detail of overall site conditions. Back of module temperature, soiling conditions, and plane of array irradiance may vary at different locations within the array. Redundant measurements may also be desired as a check to functionality of critical sensors. The best location for sensor mounting will vary depending on site topography and intended measurement purpose.

When sensors are mounted at multiple locations, select a variety of locations that will provide a representative data set for the site as a whole. Irradiance and temperature may vary across distance and elevation, so measurement locations should be chosen to be evenly dispersed across the area of the site and at various elevations if applicable. For arrays with multiple planes of array at least one measurement of irradiance and back of module temperature at each plane of array is recommended.

For redundant measurements, both devices should be mounted as close together as possible without affecting the device function.

## 4.8.1 Analog Sensors

The connections are made on the screw terminals from left to right while following the sections to come. The sections below are sorted by manufacturer. A summary of typical sensors and their connections to the integrated weather station is shown in [Table 5](#) and [Table 6](#). **Maximum one device per input.**

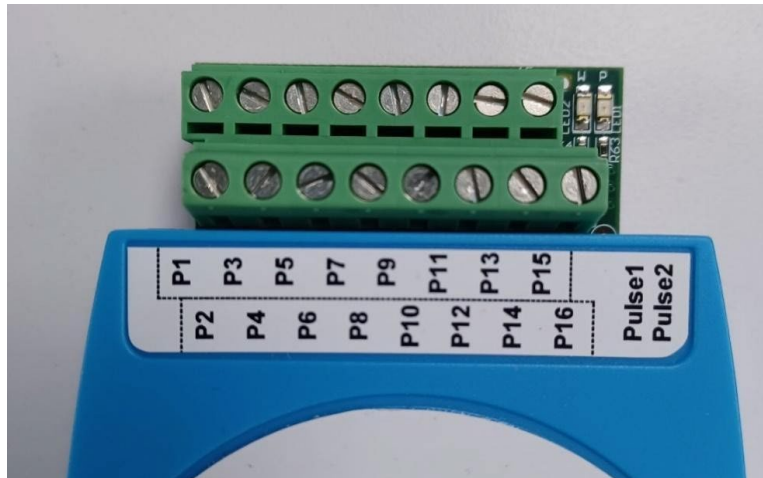

Figure 25: Integrated Weather Station Sensor Terminations

Weather Station Digitizer Terminals & Functions	
Weather Station Digitizer Terminal	Function
P1	+24 VDC
P2	+24 VDC
P3	Analog Ground/Return
P4	Analog Temperature Signal (4-20 mA)
P5	Analog Ground/Return
P6	Analog Temperature Signal (4-20 mA)
P7	Analog Ground/Return
P8	Pyranometer Signal (mV)
P9	Analog Ground/Return
P10	Pyranometer Signal/Wind Direction (mV)
P11	Analog Ground/Return
P12	+2.5 VDC (for Davis Wind Sensor only)
P13	Analog Ground/Return
P14	Wind Speed or Pulse/Dry Contact Input
P15	Analog Ground/Return
P16	Pulse/Dry Contact Input
(Chassis Ground)	Shield

Table 5: Summary of Weather Station Digitizer Terminals and Their Functions

Common Sensor Wires and Standard Weather Station Terminal Connections			
Device and Wire		Function	Weather Station Digitizer Terminal
Loop-Powered Temperature Sensor (4-20 mA), Module	Red	+24 VDC	P1
	Black	Analog Temperature Signal	P4
Loop-Powered Temperature Sensor (4-20 mA), Ambient	Red	+24 VDC	P2
	Black	Analog Temperature Signal	P6
Kipp & Zonen Pyranometer	Red	Pyranometer Signal	P8 or P10*
	Blue	Analog Ground/Return	P7 or P11*
	Black	Shield	(Chassis Ground)
Apogee Pyranometer	White	Pyranometer Signal	P8 or P10*
	Black	Analog Ground/Return	P7 or P11*
	Clear	Shield	(Chassis Ground)
Davis Anemometer	Yellow	+2.5 VDC	P12
	Black	Wind Speed	P14
	Green	Wind Direction	P10*
	Red	Analog Ground/Return	P11
Rain Collector	Red	Pulse/Dry Contact Input	P16
	Green	Analog Ground/Return	P15
Pressure Sensor	Red	+24 VDC	P2
	White	Analog Pressure Signal	P6
Relative Humidity	Red	+24 VDC	P1
	Black	Analog Humidity Signal	P4
Miscellaneous mV or $\mu$ V	Signal	Analog Temperature Signal	P8 or P10*

Pyranometer	Ground	Analog Ground/Return	P7 or P11*
-------------	--------	----------------------	------------

Table 6: Common Sensor Wires and Standard Weather Station Terminal Connections.

\* mV or uV input (P8 and P10) require gain settings via internal DIP switches. See [Pyranometer Scale](#)

The following sections provide device-specific information for common analog sensors used in Stem builds. For devices not listed, see the manufacturers' installation manuals.

### 4.8.1.1 Davis Instruments Anemometers and Rain Collectors

#### Anemometer - Wind Speed and Direction

Follow the directions that come with the anemometer to assemble and mount the sensor. Make sure to position the anemometer mount pointing true north, adjusting for magnetic declination. Connect the anemometer to the correct terminals on the weather station digitizer per [Figure 26](#).

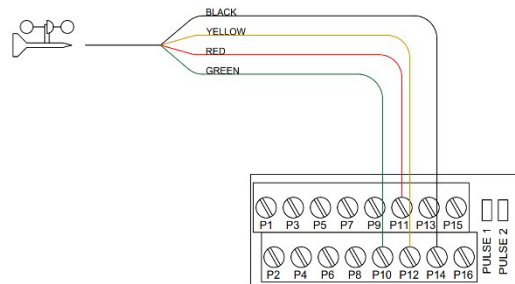

Figure 26: Davis Anemometer Wiring to IWS

#### Rain Collector

The rain collector is designed to be mounted outdoors on a level surface, away from overhead obstructions and any object that is attracted to a magnet. An unobstructed path for water runoff from the drain screen is also needed. Connect the rain collector wires to the terminals on the weather station digitizer per [Figure 27](#).

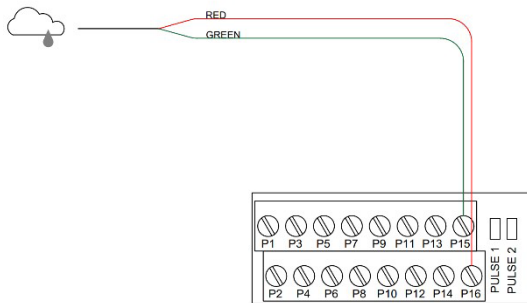

Figure 27: Davis Rain Collector Wiring to IWS

### 4.8.1.2 BAPI Enclosure Mounting

#### Module Temperature Sensor: Mounted in a BAPI Enclosure

Mount the BAPI enclosure and extend the module temperature sensor to the center of a cell in the middle of a module on the backside (see [Figure 19](#)), at least 100cm (37") from the array edge and at least 40cm (16") from the frame. Make sure the adhesive used for the sensor module is rated for up to 83°C (180°F).

### Ambient Temperature Sensor: Mounted in a BAPI Enclosure

This air temperature sensor is designed to be mounted outdoors in a north-facing, always-shaded location with the sensor pointing down. The UV-resistant plastic shield keeps the sensor protected from weather and sunlight and allows for excellent air circulation.

### Relative Humidity Sensor Mounted in a BAPI Enclosure

The relative humidity sensor is designed to be mounted outdoors. Mount the BAPI enclosure with the sensor pointing down. The UV-resistant plastic shield keeps the sensor protected from weather and sunlight and allows for excellent air circulation.

#### 4.8.1.3 Wiring the BAPI Enclosures

Note: **Do not splice or extend any of the RTD sensor wires.** It has been calibrated to provide accurate measurements. The wires leading to the Stem Integrated Weather Station can be extended up to 500 ft using 22 AWG wire.

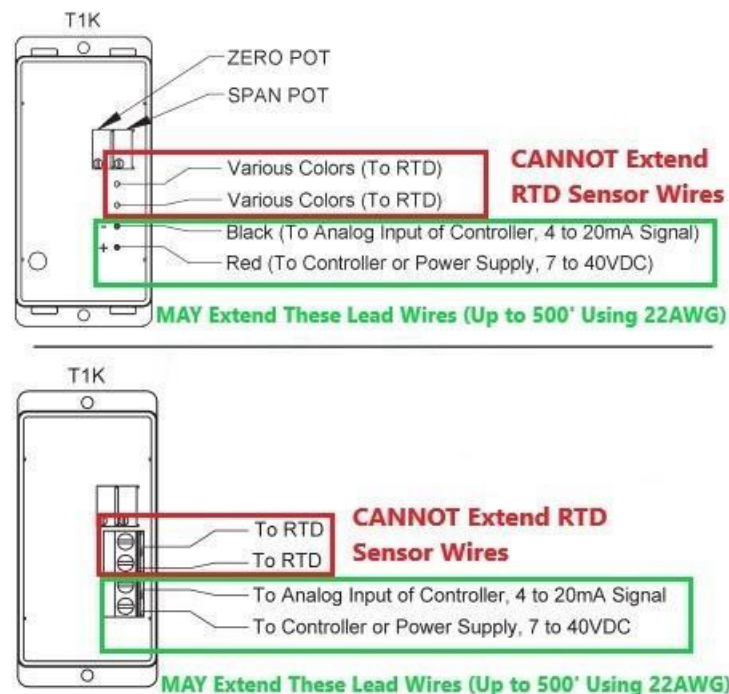

Figure 28: BAPI Wire Extension

Plug any holes in the enclosure to make it watertight. Inside the cover are red and black wires which must be extended to the weather station enclosure. Stem recommends using outdoor shielded Cat5e or better and splicing with *filled* 3M Scotchlok connectors. Connect the temperature sensors to the correct terminals on the weather station digitizer according to [Figure 29](#) for module temperature sensors, [Figure 30](#) for ambient temperature sensors, and [Figure 31](#) for humidity sensors.

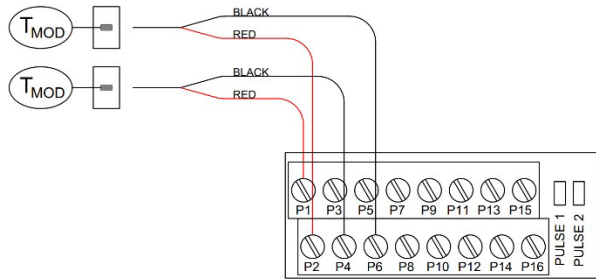

Figure 29: Loop-Powered Module Temperature Sensor Wiring to IWS

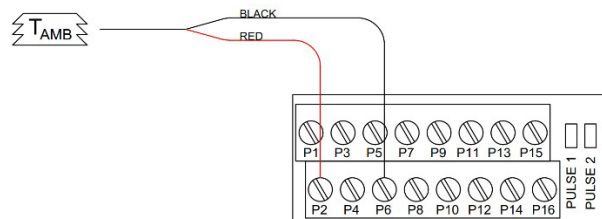

Figure 30: Loop-Powered Ambient Temperature Sensor Wiring to IWS

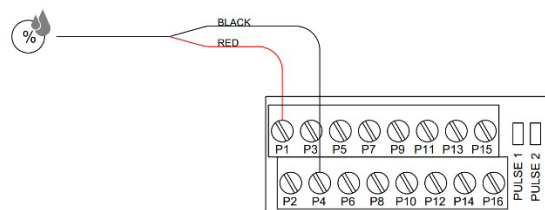

Figure 31: BAPI Humidity Sensor Wiring to IWS

#### 4.8.1.4 Kipp & Zonen Pyranometers

#### CMP3, CMP6, CMP10, CMP11, and SP Lite2 Pyranometers with Mounting Brackets

Mount the pyranometer using the included brackets and mounting hardware. Mount the pyranometer with the cable pointing north, minimizing sun exposure. See [Section 4.5.1.2](#) for specifics on the mounting location. Connect the pyranometer to the correct terminals on the weather station digitizer per [Figure 32](#) (pairing P7 with P8 or P10 with P11). The site-specific design packet will indicate which pins to use for each pyranometer.

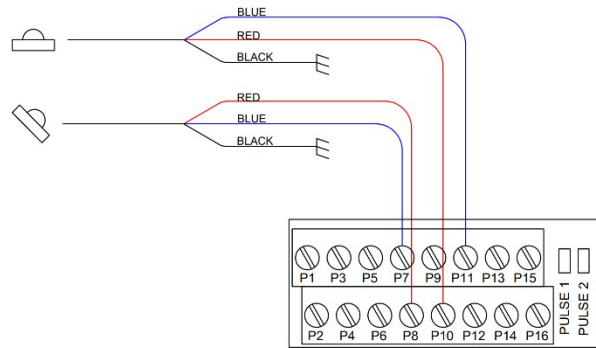
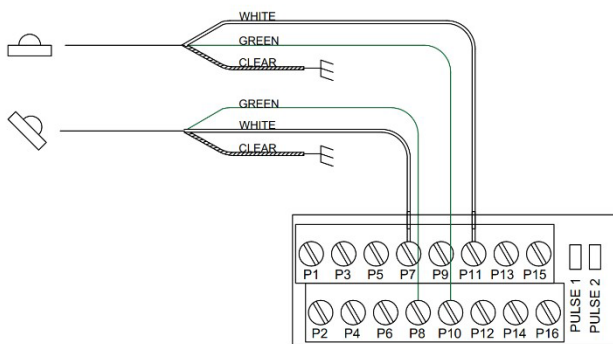

Figure 32: Kipp & Zonen Analog Pyranometer Wiring to IWS

### 4.8.1.5 Apogee Instruments Pyranometers

#### Apogee Pyranometer (SP-110, SNs 60051 and above) with Mounting Bracket



Mount the pyranometer using the included brackets and mounting hardware. See [Section 4.5.1.2](#) for specifics on the mounting location. Connect the pyranometer to the correct terminals on the weather station digitizer per [Figure 33](#) (pairing P7 with P8 or P10 with P11). The site-specific design packet will indicate which pins to use for each pyranometer. *Note: If the SN is 60050 and below, consult the manufacturer for wiring.*

Figure 33: Apogee Analog Pyranometer Wiring to IWS

### 4.8.1.6 Amphenol SSI Technologies Barometric Pressure Sensors

### Barometric Pressure

The barometric pressure sensor is designed to be mounted indoors and is usually mounted and wired in the remote weather station enclosure prior to shipping.

If the barometric pressure sensor is field installed, connect the sensor wires to the terminals on the weather station digitizer per [Figure 34](#).

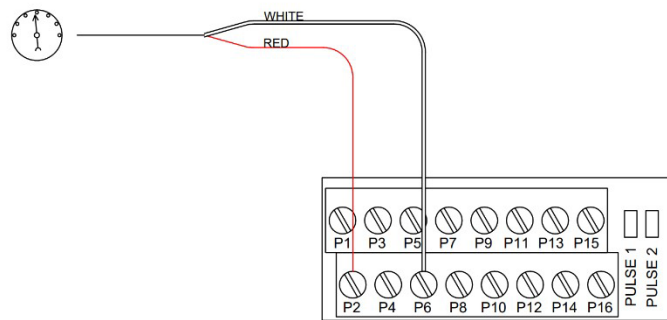

Figure 34: Pressure Sensor Wiring to IWS

## 4.8.2 Digital Sensors

The RS-485 and 24 VDC connections for digital sensors are made on the screw terminals on the unprotected terminals of the OVP-R2P1 surge suppressor. **Two sets of RS-485 data channels, labeled “CH1” and “CH2” are available - refer to the site SLD to determine which data channel to connect the pyranometer to.** The following sections are sorted by manufacturer. As these are Modbus devices, follow rules pertaining to RS-485 best practices found elsewhere in this manual.



Figure 35: OVP-R2P1 Unprotected Terminals



If a shield wire is not visible on the device cable termination, trim back the plastic insulation to reveal the braided wire jacket around the colored wires. Gather the steel braid together and connect it to the shield drain where necessary. Adding a crimp-on ferrule can make landing the braided shield easier.

Figure 36: Braided Shield

### 4.8.2.1 Hukseflux Pyranometers

### Hukseflux Pyranometers with Mounting Bracket

Hukseflux sensors communicate via Modbus independently from the Stem weather station digitizer. Mount the pyranometer using the included brackets and mounting hardware. Orient the pyranometer with the cable pointing north. See [Section 4.5.1](#) for specifics on the mounting location and [Figure 22](#) for the exact bolt pattern to attach the reference cell to the mounting plate. Connect the pyranometer to the correct terminals on the OVP-R2P1 according to the tables below.

Hukseflux SR05-D1A3 Pyranometer		
Wire Color	Terminal	Function
Brown	24VDC	V+
Black	GND	V-
Blue	Not Connected	N/A
White	CH1 or CH2 D+	RS-485+
Grey	CH1 or CH2 D-	RS-485-
Yellow	Shield/PE	Shield

Table 7: Terminal Wiring Guide for Hukseflux SR05 Pyranometers

Hukseflux SR15-D1 Pyranometer		
Wire Color	Terminal	Function
Brown	24VDC	V+
Black	GND	V-
Blue	(12VDC Only)	Heater V+
White	CH1 or CH2 D+	RS-485+
Grey	CH1 or CH2 D-	RS-485-
Yellow	Shield/PE	Shield

Table 8: Terminal Wiring Guide for Hukseflux SR15 Pyranometers

Hukseflux SR20-D2 Pyranometer		
Wire Color	Terminal	Function

Red	24VDC	V+
Blue	GND	V-
White	CH1 or CH2 D+	RS-485+
Green	CH1 or CH2 D-	RS-485-
Black	Shield/PE	Shield
Yellow	Not Connected	N/A
Brown	Not Connected	N/A
Pink	Not Connected	4-20mA+
Grey	Not Connected	4-20mA-

Table 9: Terminal Wiring Guide for Hukseflux SR20 Pyranometers

Hukseflux SR30-M2-D1 Pyranometer		
Wire Color	Terminal	Function
Brown	24VDC	V+
Black	GND	V-
Blue	CH1 or CH2 COM	RS-485 Common
White	CH1 or CH2 D+	RS-485+
Grey	CH1 or CH2 D-	RS-485-
Yellow	Shield/PE	Shield

Table 10: Terminal Wiring Guide for Hukseflux SR30 Pyranometers

#### 4.8.2.2 Kipp & Zonen Pyranometers

##### **SMP3, SMP6, SMP10, SMP11, and SMP12 with Mounting Brackets**

Mount the pyranometer using the included brackets and mounting hardware. Mount the pyranometer with the wire pointing north, minimizing sun exposure. See [Section 4.5.1](#) for specifics on the mounting location

and [Figure 22](#) for the exact bolt pattern to attach the reference cell to the mounting plate. Connect the pyranometer to the correct terminals on the OVP-R2P1 per the tables below.

Kipp & Zonen SMP3, SMP6, SMP10, and SMP 11 Pyranometers		
Wire Color	Terminal	Function
White	24VDC	V+
Black	GND	V-
Yellow	CH1 or CH2 D+	RS-485+
Grey	CH1 or CH2 D-	RS-485-
Blue	CH1 or CH2 COM	RS-485 Common
Shield	Shield/PE	Shield
Red	Not Connected	N/A
Green	Not Connected	4-20mA+
Brown	Not Connected	4-20mA-

Table 11: Terminal Wiring Guide for Kipp & Zonen SMP3, SMP6, SMP10, and SMP11 Pyranometers

Kipp & Zonen SMP12 Pyranometer		
Wire Color	Terminal	Function
White	24VDC	Power 1: V+
Black	GND	Power 1: V-
Yellow	CH1 or CH2 D+	RS-485+
Grey	CH1 or CH2 D-	RS-485-
Blue	CH1 or CH2 COM	RS-485 Common
Shield	Shield/PE	Shield
Red	24VDC	Power 2: 24V+
Green	Not Connected	N/A

Brown	GND	Power 2: 24V Common
-------	-----	---------------------

Table 12: Terminal Wiring Guide for Kipp & Zonen SMP12 Pyranometers. The SMP12 Requires Two Pairs of Wires Connected to 24 VDC Power.

### RT1 Pyranometer

Mount the RT1 sensor at the corner of the PV panel using the thumb screw to tighten in place. Alternatively, install the side mount adapter and secure to the side of a panel with the included clip. The 20 m 5-pin cable will connect the RT1 to the DAS. The 3 m 2-pin cable will connect the temperature sensor to the RT1 housing. Affix the back of the module temperature sensor probe to the center of the back of the module away from the edge of the array. Locate the RT1 away from roads, trees, buildings, and other obstructions that may cast a shadow or interfere with temperature readings.

**Note: Do not extend the 2-pin cable.** The 5-pin cable may be extended following RS-485 daisy chain configuration best practices. Connect the RT1 to the correct terminals on the OVP-R2P1 per [Table 13](#) below.

Kipp & Zonen RT1		
Wire Color	Terminal	Function
Red	24VDC	V+
Blue	GND	V-
Yellow	CH1 or CH2 D+	RS-485+
Grey	CH1 or CH2 D-	RS-485-
Green	CH1 or CH2 COM	RS-485 Common
Shield	Shield/PE	Shield

Table 13: Terminal Wiring Guide for Kipp & Zonen RT1

If the power cable with the RT1 is yellow, consult the manufacturer for wiring.

### 4.8.2.3 Lufft WS Series Meteorological Stations

#### Lufft WSXXX-UMB Series Meteorological Stations

Mount the station at the top of the mast. Minimum 2 m (6'7") above the ground for sensors with wind measurement and 4.5 m (14'9") for sensors with a radar precipitation sensor. Tighten the mounting nuts evenly until the mast clamp contacts the mast and then tighten an additional 3 full revolutions of each nut. For accurate wind direction readings, use an aluminum mast. Locate the sensor away from roads, trees, buildings, and other obstructions as they can interfere with wind measurements. Falling leaves and other moving objects may cause false readings from the radar precipitation sensor.

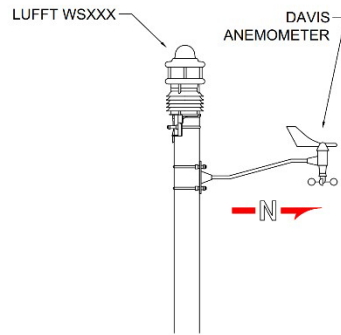

Figure 37: Pole-Mounted Sensors

Connect the station to the correct terminals on the OVP-R2P1 per [Table 14](#) below. The provided cable for power and RS-485 data may be extended following RS-485 daisy chain configuration best practices.

Lufft WSXXX-UMB Meteorological Stations		
Wire Color	Terminal	Function
Brown	24VDC	V+
White	GND	V-
Green	CH1 or CH2 D+	RS-485+
Yellow	CH1 or CH2 D-	RS-485-
Red	24VDC	Heater V+
Blue	GND	Heater V-
Shield	Shield/PE	Shield
Pink	Not Connected	N/A
Grey	Not Connected	N/A

Table 14: Terminal Wiring Guide for Lufft WSXXX-UMB Meteorological Stations

#### 4.8.2.4 IMT Solar Reference Cell and Temperature Sensors

##### MT Silicon Irradiance Sensor (Reference Cell)

The reference cell is to be mounted directly to the array. See [Figure 22](#) for the exact bolt pattern to attach the reference cell to the mounting plate. If a plug-in temperature sensor is to be used it should be

mounted to the back of a module, away from the edge of the array. Connect the reference cell wires to the terminals on the Unprotected side of the RS-485 overvoltage protector (OVP-R2P1) per [Table 15](#) below. The OVP-R2P1 has two channels - take care to connect to the correct channel by referencing the site SLD. If the thick black shield wire does not exist, gather and twist together the mesh wiring wrap that's around the colored wires and use that as the shield. A ferrule may be added to make affixing to a screw terminal easier.

#### IMT vWind-Si Wind Speed Sensor

Mount in the vertical position to prevent water from entering the sensor. Do not install on a roof inclination or in wind protected areas. Install in the middle of a flat roof. The cable connects via the 2-pin connector on the reference cell. Apply dielectric grease to the port before plugging the sensor in.

#### IMT Tamb-Si Ambient Temperature Sensor

Mount the ambient temperature sensor in a shaded location via the included bracket. The cable connects via the 3-pin connector on the reference cell.

#### IMT Tmodul-Si Back of Module Temperature Sensor

Affix the back of the module temperature sensor to the center of the back of a cell away from the edge of the array. The cable connects via the 3-pin connector on the reference cell.

#### IMT Ta-ext-RS485-MB Ambient and Tm-RS-485MB Back of Module Temperature Sensors

These sensors come equipped with an aluminum housing and a weatherproof cable. If mounted outdoors, avoid direct exposure to sunlight and rain to the sensor housing. The through holes used to fix the sensor to a stable surface will be accessible when the housing is opened. Mount the ambient temperature sensor in a shaded location via the included bracket. Affix the back of the module temperature sensor to the center of the back of a cell away from the edge of the array. It does not connect to the reference cell and should be instead connected to the terminals on the OVP-R2P1 per [Table 15](#) below.

The IMT devices are equipped with a 3 m cable for power and RS-485 data. The cable may be extended following RS-485 daisy chain configuration best practices.

IMT Reference Cell and Temperature Sensors		
Wire Color	Terminal	Function
Red	24VDC	V+
Black	GND	V-
Brown	CH1 or CH2 D+	RS-485+
Orange	CH1 or CH2 D-	RS-485-
Black (Thick)/Mesh Wire	Shield/PE	Shield

Table 15: Terminal Wiring Guide for IMT Weather Sensors

#### 4.8.2.5 Kipp & Zonen DustIQ Soiling Station

Select the soiling station mounting location based on expected site soiling conditions. Multiple sensors may be distributed throughout the array to produce multiple data points that may be used to extrapolate overall site soiling conditions. Ideal mounting location will vary for every site – for best results, consider the surroundings, environment, and prevailing wind directions when selecting the mounting location.

Mount directly to the PV array racks using the included brackets. See the Kipp & Zonen DustIQ installation manual for additional mounting information.

Connect the 8-pin waterproof connector of the device cable to the DustIQ “Host” terminal. Connect the pigtail wires to the OVP-R2P1 per [Table 16](#). Unused wires should be trimmed and taped.

Kipp & Zonen DustIQ Soiling Station		
Wire Color	Terminal	Function
White	24VDC	V+
Black	GND	V-
Yellow	CH1 or CH2 D+	RS-485+
Grey	CH1 or CH2 D-	RS-485-
Blue	CH1 or CH2 COM	RS-485 Common
Shield	Shield/PE	Shield
Pink	Not Connected	N/A
Green	Not Connected	N/A
Brown	Not Connected	N/A

Table 16: Terminal Wiring Guide for Kipp & Zonen DustIQ Soiling Stations

### 4.8.3 Stem Weather Station Junction Boxes

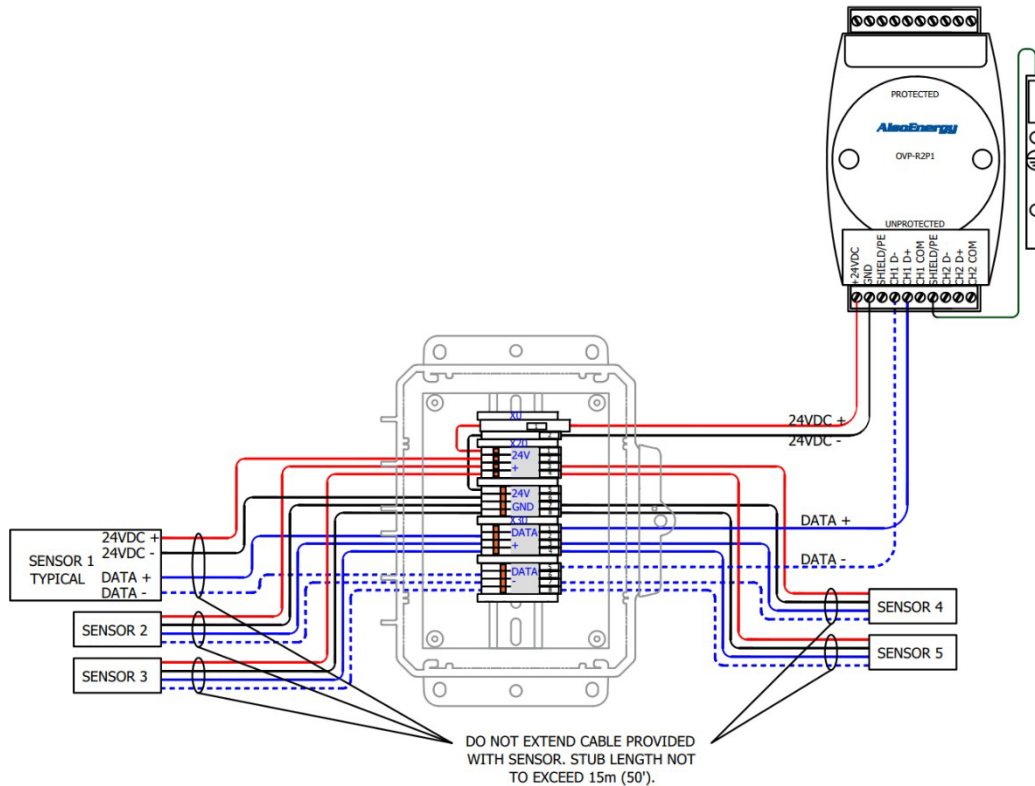

Figure 38: Stem Weather Station Junction Box Connections

The Stem weather station junction box (WS-JB-01) includes bridged terminal blocks mounted inside of a NEMA 4X enclosure. Terminals are provided for both 24 VDC sensor power and RS-485 data wires.

Up to (5) RS-485 sensor pigtails may be connected at one junction box.

Install one junction box at each sensor location. The RS-485 trunk between junction boxes and DAS client may be extended following RS-485 best practices (see [Section 4.2.3](#)). Wires connecting the sensor to the junction box must not be extended beyond 15 m (approximately 50') to avoid star configuration and communication failures.

Cable shield must be connected to earth ground at one end of the cable. Avoid ground loops caused by landing shield at both ends of a cable run.

Stem Weather Station Junction Box Terminals		
Bus	Terminal	Function
X0	1	Input 24 VDC+ with 4A Fuse
	2	Input 24 VDC GND
X20	1	24 VDC+ to Sensors
	2	
	3	
	4	
	5	24 VDC GND to Sensors
	6	
	7	
	8	
X30	1	RS-485 Data+ to Sensors
	2	
	3	
	4	
	5	RS-485 Data- to Sensors
	6	
	7	
	8	

Table 17: Stem Weather Station Junction Box Terminals

## 4.9 Uninterruptible Power Supply (UPS) Installation

Because of possible electrical shock or fire hazards, the connection of this equipment should only be made by qualified personnel in compliance with applicable local electrical codes and standards.

### 4.9.1 UPS Wiring

Ensure breaker Q-P# (X9:1) is in the OFF position and AC supply power is OFF at the source. Ensure FUPS# fuse holder is OPEN.

Ensure F-BAT# fuses have been REMOVED from battery connection module.

## 4.9.2 Make / Check Connections

- Ethernet port located on underside of charge controller to local area network using CAT5E or CAT6 cable
- Terminal X9:1 to AC input Line
- Terminal X9:2 to AC input Neutral
- Terminal X9:3 to PE
- Terminal X103:1 and/or X103:2 to 24 VDC Output +
- Terminal X103:3 and/or X103:4 to 24 VDC Output Common
- Terminal X101:1 to battery connection module positive contact (+)
- Terminal X101:2 to battery connection module negative contact (-)
- Terminal X101:3 to battery connection module signal contact (pulse symbol)
- (BAT A+) to battery A positive contact
- (BAT A-) to battery A negative contact
- (BAT B+) to battery B positive contact
- (BAT B-) to battery B negative contact

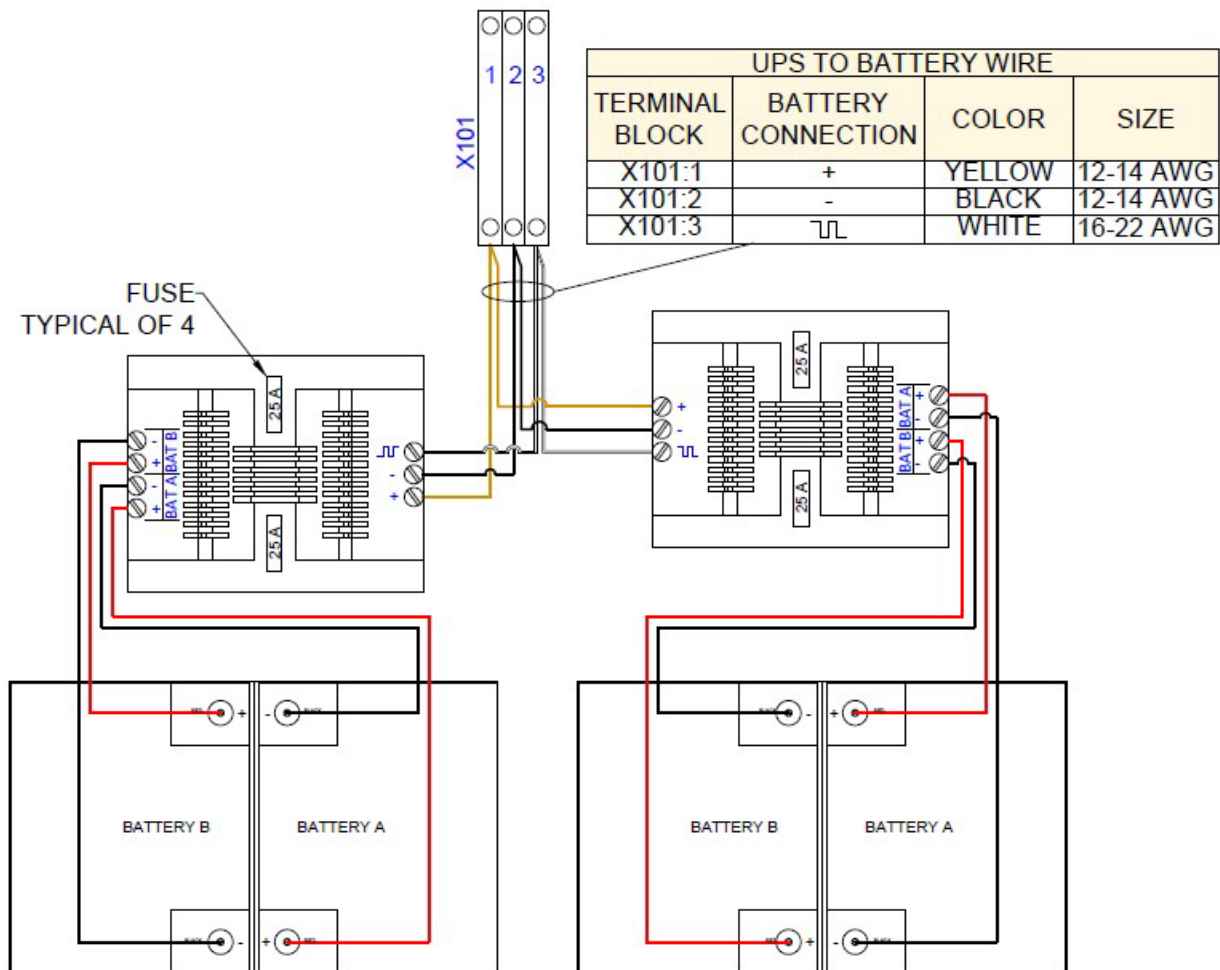

Figure 39: Series (Dotted Box Only) and Parallel (Complete Image) Battery Wiring Diagram

### 4.9.3 Energize System

**When the site is ready to be energized**, insert F-BAT# fuses into the battery connection module. Connecting batteries for prolonged periods without charging will result in decreased battery life and possible battery failure.

Energize the enclosure at breaker Q-P# (X9:1).

Insert F-UPS# fuse and close fuse holder.

## 4.10 Transformer Dry Contact Monitoring

Stem default settings for transformer monitoring include the five contacts listed in [Table 18](#). These are assumed to be Normally Closed contacts. If the transformer on site does not have all contacts showing, leave unused terminals empty and connect all of the available contacts to the terminal blocks indicated in [Table 18](#). If the system will not use all 5 contacts or has only normally open contacts, contact Stem Support after wiring is completed with a full description of the contacts being monitored to modify alarm settings to match the completed system.

Connect the transformer signal wires for the contacts listed in [Table 18](#) to the corresponding terminals on the transformer’s interface bus (IO# X80). All contacts use a shared common connection to terminal block 6.

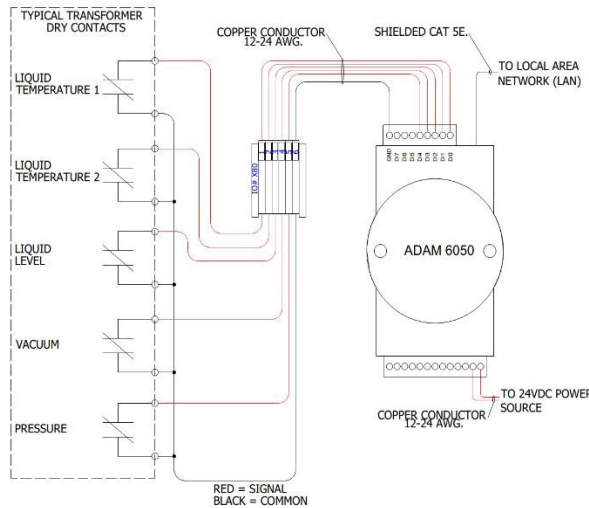
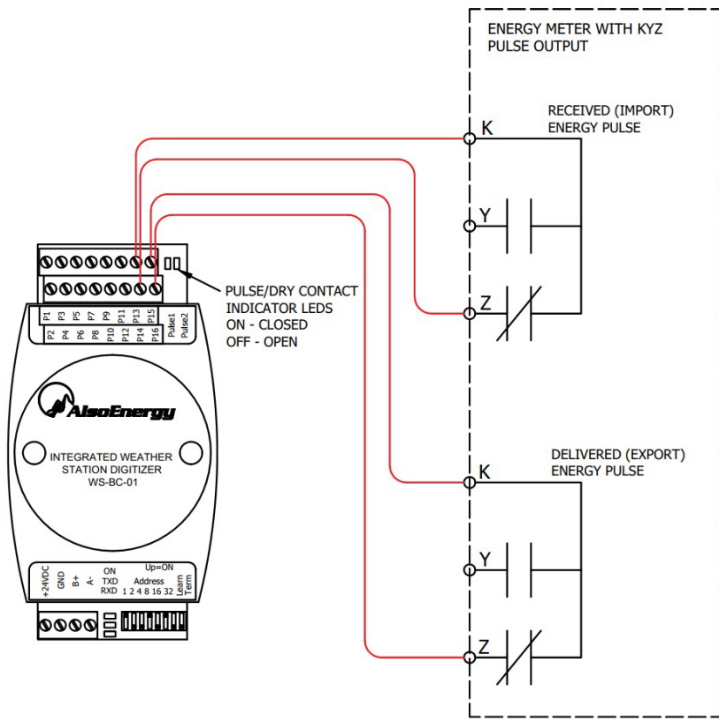

Figure 40: Transformer Dry Contact Monitoring Diagram

Transformer Dry Contacts		
I/O Interface Bus	Terminal #	Transformer Alarm Contact
IO# X80	1	Liquid Temperature 1
	2	Liquid Temperature 2
	3	Liquid Level
	4	Vacuum
	5	Pressure

Table 18: Transformer Dry Contact Monitoring Connections

## 4.11 KYZ Pulse Meter



Connect K and Z terminals as shown in [Figure 41](#) and [Table 19](#). The Y contact is not used.

A watt-hours per pulse scale is required for accurate meter data. Wh/pulse is set within the meter and must be recorded in the meter settings on PowerTrack.

Connect both received and delivered contacts for all bidirectional meters. One digitizer must be used for each meter.

Pulse contact LED indicators will blink once for each pulse received from the meter.

Diagram

Figure 41: KYZ Pulse Meter

KYZ Pulse Meter Contacts	
Meter Contact	Stem IWS Digitizers Terminal Block
Delivered Energy K	P15
Delivered Energy Y	N/A
Delivered Energy Z	P16
Received Energy K	P13
Received Energy Y	N/A
Received Energy Z	P14

Table 19: KYZ Pulse Meter Contact Terminal Connections

# 5 Troubleshooting

## 5.1 Power Connections

Devices' status LEDs can be used to determine if power is not properly being delivered throughout the system. If one or more devices' LEDs indicate that they are not powered on, use voltage readings to determine where the problem lies.

If no device appears to be powered, verify that the voltage of the primary enclosure power input (see [Figure 6](#)) matches the expected value. Check the input and output of all power supplies. If a power supply is getting the appropriate AC input voltage but does not measure a sufficient DC output voltage, the power supply must be replaced.

If devices upstream of a fuse are powered but those downstream are not, this suggests a high likelihood of a blown fuse. If this is confirmed by a failed continuity test on the fuse, replace the fuse with one of the same rating and form. If the fuse shows continuity, make sure that it is properly inserted into the fuse holder, and that the fuse holder closes completely with no interference.

If it appears that power is being properly distributed to the enclosure, the power supplies are providing 24 VDC, and fuses are good, but some devices are still not receiving power, check voltages down the line until you find the location of the discontinuity. Verify that wires are properly seated in terminals and that the ferrule insulation is not interfering with connectivity. Reduce possible sources of failure by running a direct connection from a device to its power supply. If a device will not power on with a direct connection to a power supply that has been verified to be in working condition, then it is likely that the device is faulty and should be replaced.

## 5.2 PowerLogger 1000

### 5.2.1 Screen Calibration

If there are issues with the touchscreen interface, screen calibration can be accessed by tapping the screen 3 times during startup.

### 5.2.2 No PowerTrack Connection

Check the Last Upload and Last Heartbeat on the main screen. The device should heartbeat approximately every 3 minutes. Occasional missed heartbeats are normal, but repeated or extended communication outages from the data logger may indicate problems with the network hardware or configuration, or unreliable internet access. To check the logger's configuration settings, follow the steps below:

- Select Network. If set to Static, ensure that the logger's IP address, subnet mask, and gateway match the information on the single-line diagram.
- Within the Network screen, click Quick Test, then Start to view if the network is up and the Stem server can be reached.

- Check that the cellular modem or other Internet connection is online.
- Check cable and LED pattern of the logger’s Ethernet port – the green LED should be solid for a persistent connection and the yellow LED should periodically flash on data TX/RX.

### 5.2.3 RS-485 Devices Not Responding in PowerTrack

- Navigate to Utilities > Port Tools > Port Scan.
- Select Baud Rate and Port Number for the device that isn’t responding, and press Start. The output will show “OK” for any device addresses that have been detected on the bus.
  - If “ERR” shows when an address should be detectable, there is probably a physical layer issue, e.g., wiring. Check the RS-485 bus.
  - If “OK” but no device heartbeat in PowerTrack after 30 minutes, contact Stem Support

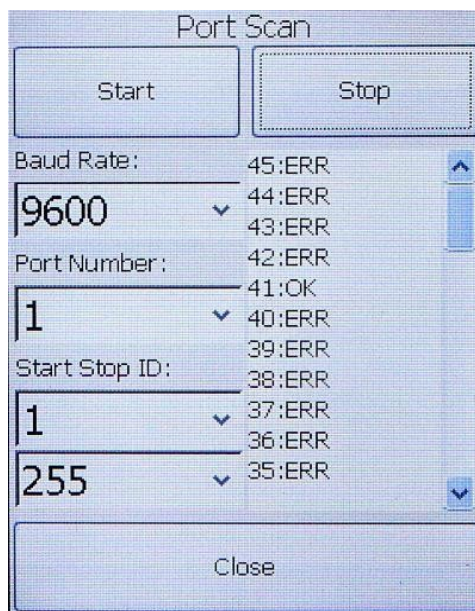

Figure 42: PowerLogger 1000 Port Scan Screen

## 5.3 Data Logger Does Not Communicate with an End Device

- Refer to the supplied Single Line Diagram to see how devices are connected, and the Communications Table to see configuration information.
- Verify the power at the device.
- Verify Modbus wiring to the device.
- If channels appear correctly arranged, but there is still no communication, attempt to switch the RS-485 lines. Note the starting configuration.

- Verify device Modbus address and communication parameters.
- Refer to the [Port Scan instructions](#) to confirm the device is being read by the data logger.
- If this does not resolve the communication problem, contact Stem Support to troubleshoot the device.

## 5.4 RS-485 Modbus Troubleshooting

Most problems are caused by improper or broken wiring. If only the first three devices in a daisy chain of twelve are communicating, then there is likely a wiring problem or failed device communication card at device three or four.

1. Verify the Modbus connections are secure, and enough insulation has been removed to establish an electrical connection at the terminal.
2. If using solid-strand wire, verify that the wires are not broken in insulation. Stem strongly recommends stranded wire for all communication wires.
3. Verify that devices are daisy-chained and not in a star configuration, i.e. maximum of two wires on any terminal.
4. Verify the data logger is powered up and configured to poll the correct Modbus addresses and is using the correct driver for each device.
5. If the RS-485 cable length is longer than 30 feet, verify that shielded cable is used, and the shield is grounded at only one end. Shielded cable is always recommended for resistance to interference.
6. Ensure that the RS-485 common wire is connected in addition to the data+ and data- wires if the connection is available on the device. Some devices do not include a common (ground) connection for the RS-485, however it should always be connected if possible.
7. Often, devices will specify the terminal connections as A/B instead of +/- . There is no standard correlation, and many devices will label Data+ as A while others will label as B. Check the user manual of the device(s) in question to confirm polarity. If polarity cannot be determined from documentation try reversing Data+ and Data- to see if the device will respond, this will not damage devices and is often the simplest way to confirm polarity standard of a device when documentation is not clear.
8. Ensure that each device is assigned a unique address and that the address and bus configuration including baud rate, parity, data, and stop bits of the unit in question is identical to the configuration as shown on the single-line diagram and PowerTrack.

## 5.5 Meter

### 5.5.1 Voltage Readings Not as Expected

If there are issues with the touchscreen interface, screen calibration can be accessed by tapping the screen 3. Confirm that the voltage readings when measured L-L or L-N match those reported in PowerTrack. If the system includes medium voltage potential transformers the transformer ratio must be correctly entered for accurate scaling. Contact Stem Support if there is a mismatch.

If voltage readings are 0, check that the fuses are intact by performing a continuity test with your digital multimeter. If continuity is not found between the ends of a fuse, it must be replaced by a 600V 0.5 A Class CC fast-acting fuse.

## 5.5.2 Current Readings not as Expected

Verify that the CT ratio entered in PowerTrack matches that on the meter.

For meters using 5A CTs, ensure that the shorting tabs are dropped at the input of the meter and at the CT test switch if present. The meter will still read some current while the shorting pins are engaged, but it will be a small fraction of the expected value.

## 5.5.3 Identifying Swapped CT Phases

If current and voltage readings are all within expected ranges, but power is less than expected, this may be a symptom of a phase alignment mismatch between voltage reference and current transformer.

Confirm that the Power Factor reported in PowerTrack is 0.9 or above. If not, verify that your voltage and current is matched phase-to-phase. See [Figure 18](#) for a diagram showing proper phase-to-phase wiring. Trace the wiring between the meter and feeder circuit, and ensure that it is wired as shown in [Figure 18](#). If there are two phases with power factors equal to 0.5 and -0.5 then this indicates that they are swapped with each other.

# 5.6 Internet Access

If devices appear to be functioning, but no data is being uploaded to PowerTrack, there may be a lack of internet access to the system. When using an Stem -supplied modem with an antenna, make sure the antenna is well positioned according to [Section 4.4](#). Many – but not all – modems will have LEDs to indicate signal strength, which should be used to determine the best placement.

To verify that the network can reach the internet, connect your laptop into an open Ethernet port on an installed network switch. Configure your Ethernet port for DHCP. Attempt to reach [home.Stem.com](http://home.Stem.com). Other sites may be blocked by security measures and should not be used to test network connectivity. Contact Stem Support if an Stem -supplied modem is still not providing access to the internet after taking these steps.

If internet access is customer-supplied, contact the Network Administrator for further troubleshooting steps – Stem Support cannot assist with these networks.

# 5.7 Stem Weather Station

The Stem Weather Station consists of a variety of analog sensors that connect to an integrated Signal Conditioner / Digitizer. The digitizer reads the analog signals and converts them to a digital value that is sent to the Stem Data Logger via a Modbus RTU connection.

## 5.7.1 Weather Station Communication Issues

- Check the data logger is working:
  - The green “ON” LED will flash approximately once per second when power is connected.
  - The TXD and RXD LEDs flash when data is transmitted/received.
- Check Modbus Address on the DIP switches. These must correspond to the address assigned on the single-line diagram as well as the address setting for the weather station in PowerTrack. • Check RS-485 connection, + to +, - to -

## 5.7.2 Weather Station Sensors

If the weather station is communicating but sensor readings are wrong, check the sensor troubleshooting listed below:

### 5.7.2.1 Temperature Sensors

- Measure the voltage between the terminals where the sensor is connected. It should be between +18 and +22 VDC.
- If it is not, inspect wiring for an open or short circuit.
- If wiring is confirmed good and the voltage measurement is still outside of the expected range, replace the signal conditioner / digitizer assembly.

### 5.7.2.2 BAPI Temperature Sensors (4-20 mA, Ambient -29°C to 49°C or Back of Module - 40° C to 85° C)

- Voltage test to determine if the sensor is malfunctioning:
  - Measure the voltage between the device sensor terminal (P4 or P6) and the common ground terminal P5.
  - The voltage should be about 4.2 V at 80°F for an ambient temperature sensor or 3.3 VDC at 80°F for a back of module temperature sensor. If the voltage is less than 1 VDC at normal temperatures, the sensor is not connected correctly or needs to be replaced. If the voltage is higher than 5 VDC, inspect the black card in the sensor housing for damage. If no damage is visible, connect the black wire to the other temperature input terminal (P4 or P6) and measure the voltage between the black wire terminal and P5. If this voltage is also greater than 5VDC then the temperature sensor is likely faulty and should be replaced. If the voltage is within normal limits on one of the temperature inputs but not the other, then the input port may be damaged and the digitizer should be replaced.

### 5.7.2.3 Wind Direction

The voltage between Wind Direction P10 GRN and P11 Red indicates the direction the wind vane is pointing: 0 V for North, 0.625 V for East, 1.25 V for South and 1.875 V for West. If the Wind Direction is incorrect, check the voltage between P12 YEL and P14 Blk. It should be 2.5 V. If it is not, remove the P12 YEL sensor wire and re-measure P12 YEL to P14 Blk. If it is 2.5 V, replace the wind vane / anemometer assembly. Otherwise, replace the integrated weather station.

Rotate the wind vane. The voltage between wind direction P10 GRN and P11 Red should change. If it does not, remove the sensor wire on P10 GRN and repeat the test. If the voltage changes, replace the integrated weather station; otherwise, replace the wind vane.

If the voltage readings are correct but PowerTrack data is incorrect, verify that the S2 DIP switches (pair on the right) are both in the Up position.

#### 5.7.2.4 Calibrate the Wind Vane

- Slowly turn the wind direction shaft until the voltage between Wind Direction GRN (P10) and Red (P11) is zero.
- Being careful to keep the stainless-steel shaft from turning, place the wind vane on the shaft with the bullet-shaped nose of the vane pointing north.
- Slide the wind vane down onto the shaft as far as it will go.
- Use the Allen wrench provided to tighten the set screw on the side of the wind vane.

#### 5.7.2.5 Wind Speed

The yellow LED at the top-right of the digitizer card flashes once per revolution of the anemometer cups. If it does not, disconnect the P14 Wind Spd BLK wire. The LED should be OFF. With a short piece of wire, connect Wind Speed terminals P11 to P14. The LED should be on. If the LED toggles, the wind sensor, or its wiring, is bad. If the LED does not toggle during this test, replace the integrated weather station.

### 5.7.2.6 Pyranometer Scale

The mV input terminals can be configured for a variety of signal magnitudes by changing the position of the channel gain DIP switches. If these switches are set correctly for the magnitude of the input signal the readings may be altered by a factor of 10 or 100. To change the gain settings, unscrew the two screws on the front of the Stem weather station digitizer and remove the cover. Note two sets of DIP switches on the upper left side of the board ([Figure 43](#)).

Most pyranometers provide a signal of 5-30  $\mu\text{V}$  per  $\text{W}/\text{m}^2$  which requires both gain switches to be in the Down position. Some pyranometers, such as the Apogee SP-110, output greater voltages and require the gain switches to be set Down-Up (from left to right). Refer to [Table 20](#) for correct gain switch settings. Check that the gain switches are in the correct position and sensitivity value from the pyranometer calibration certificate is correctly entered in PowerTrack.



Figure 43: IWS Board Highlighting Gain Switches

Gain Switch Settings		
Left Switch	Right Switch	Use
Down	Down	Low-level pyranometers (Kipp & Zonen, Hukseflux, LiCor)
Down	Up	High-level pyranometers (Apogee)
Up	Up	Anemometer (Wind Speed and Direction)

Table 20: Gain Switch Settings per Device

## 5.8 UPS

The LEDs on the UPS can provide guidance regarding any problems that may occur with the uninterruptible power supply.

If power output is not as expected through the UPS, verify that the fuses at the batteries and on the UPS system output are correctly inserted and intact. Fuses are present at the battery and at the UPS power output circuit. Replace as needed. Check wiring for loose or broken terminations.

If the UPS functions normally but is providing reduced backup duration, the batteries may be near end of life and should be replaced.

For more in-depth UPS troubleshooting, contact Stem Support.

## Stem Support Track

*Direct access 7 days a week to best-in-class support resources and specialists*

**Open a Case:** <https://home.alsoenergy.com/support>

### For Onsite Appointments:

If you know you are going to be onsite, it's best to schedule an appointment beforehand with our call center support staff.

**Use our easy scheduling tool:** [alsoenergysupport.setmore.com](https://alsoenergysupport.setmore.com)

If you would like to schedule a site visit from an Stem Field Technician, please send an email to [onsiteservice@alsoenergy.com](mailto:onsiteservice@alsoenergy.com)

### For Phone Assistance:

**Contact us at 866-303-5668**

Weekdays: 8 am – 9 pm US-EST

Weekends: 11 am – 7 pm US-EST

### For Software Training:

**Schedule 1-on-1 training:** [alsoenergytraining.setmore.com](https://alsoenergytraining.setmore.com)

For video tutorials, login to PowerTrack and go to the Help menu, then select "Videos & Training".

**NOTE:** Use your PowerTrack username and password to login.