

# Installation Manual

Version 21.2

## PowerManager CS

Data Logger for Photovoltaic Power Plants

Integrated PV Utility Control and  
Grid Stability Management System Ethernet

enabled I/O Gateway



The image may deviate from the real equipment

This manual is protected by copyrights. No parts of it may be copied or transferred into other languages without the express prior written consent of Stem Inc.

The utmost care and attention have gone into the preparation of this operation manual, but Stem accepts no liabilities for errors that may be contained in the operation manual or may result from using the operation manual.

The registered trademarks used in this operation manual are the property of their respective owners.



This product conforms with the low-voltage directive 2006/95/EG and the EMC directive 2004/108/EG. The certificates can be obtained from the manufacturer Stem Inc.

© 2021 Stem Inc, Boulder, CO USA.  
All rights reserved. Subject to technical changes.

Stem GmbH  
Franz-Ehrlich-Strasse 9  
D-12489 Berlin  
  
Phone: +49 (0) 30 / 338 430-0  
Fax: +49 (0) 30 / 338 430-99  
Email: eurosales@alsoenergy.com

Stem Japan K.K  
617 MG Meguro Ekimae  
2-15-19, Kamiosaki, Shinagawa-ku  
Tokyo 141-0021, Japan  
  
Phone: +81 3 4530 9502  
Email: apacsales@alsoenergy.com

Stem India  
303-Solitaire Plaza  
Sikandarpur, Gurgaon  
India-122002  
  
Phone: +91-7506247799

Stem Inc  
105 Edgeview Dr, Suite 450,  
Broomfield, CO 80021  
  
Phone: +1 866 303 5668  
Email: contactus@alsoenergy.com

## Table of Contents

1. Instructions for the Use of the Manual.....	6
1.1. Target Group .....	6
1.2. Icons .....	6
1.3. Contents.....	6
2. Storage and Transportation .....	6
3. Safety .....	7
4. Scope of Delivery.....	7
5. Setup .....	7
6. Product Description .....	9
7. Design .....	10
7.1. Power Supply Module (optional).....	11
7.2. Monitoring & Network Module .....	12
Fig 6. Heating option .....	12
7.3. Connection Module .....	13
8. Connection of Data Communication.....	14
8.1. Connecting the Ethernet Cable .....	14
8.2. Connecting Digital Inputs.....	14
8.3. Connecting Temperature Sensors .....	15
8.4. Connecting Digital Outputs.....	15
8.5. Connecting Analog Inputs.....	16
8.6. Connecting Analog Outputs.....	17
8.7. Connecting S0-Interface (counter).....	18
8.8. Connecting RS485 Bus Devices.....	19
8.9. Terminating the RS485 Bus.....	21
8.10. Commissioning the Router .....	22
8.11. Commissioning the VPN-Router .....	23
8.12. Connecting the Cable Shield .....	23
8.13. Splice Box - Removal and Installation .....	24
9. Connecting Power Supply.....	26
9.1. Installing and Connecting the Batteries .....	26
9.2. Connecting the Earthing Cable.....	27
9.3. Connecting the AC Main Cable .....	27

10. Energize / De-Energize .....	27
11. Connecting External Battery Box.....	27
12. Mounting Pyranometers/Reference Cells.....	28
12.1. Sensor Mounting Plate .....	28
12.2. Mounting the Sensor Mounting Plate.....	29
12.3. Mounting a Pyranometer .....	31
12.4. Mounting a Reference Cell .....	32
13. Starting up .....	33
13.1. Checking the Connections.....	33
13.2. Starting the Data Communication.....	33
13.3. Starting the Device in Battery Mode .....	33
14. Maintenance .....	33
14.1. User Maintenance .....	33
14.2. Manufacturer’s Service.....	34
14.3. Spare Parts .....	35
15. Liability .....	37
16. Technical Data .....	38







# 1. Instructions for the Use of the Manual

## 1.1. Target Group

This installation manual is intended for qualified technical personnel such as technicians, installation and planning personnel in charge of the installation and setup of the unit.

## 1.2. Icons

Warnings and notes are provided with icons as follows:

	<b>Warning - danger to life by high electrical current</b>
	<b>Warning - danger to life by high electrical voltage</b>
	Follow the hints and instructions given in the manual.
	Recommends actions to improve situations and enhance operation safety. If you do not act as stated, however, safety is not jeopardized nor does this lead to any malfunction or destruction.

Stem is used in the text instead of the full company name Stem Inc.

## 1.3. Contents

The installation manual provides information about the safe and proper installation of the equipment to ensure efficient operation and use. Please read the manual carefully prior to installing the equipment and putting it into service. Make sure that you keep the manual in the dedicated place in the cabinet door.

The contents of this manual do not, however, replace any technical knowledge. Such expertise is subject to the user's training or further education. Acquiring special knowledge is solely subject to the user of the equipment.

Stem is not liable for damage due to installation and use of the equipment not in compliance with the law.

# 2. Storage and Transportation

Make sure not to expose the unit to direct sunlight or to rain water. Transport and store the unit in its original packaging in dry and dust-free conditions on a pallet. This will protect the external connectors from damage, dust and dirt.

	Make sure not to bend the fibre-optic cables as they will irreparably break.
---	--

## 3.Safety

---



**Risk of death! The device is powered by AC voltage.**  
**Before installation, maintenance, cleaning or repair work, switch off the power supply and secure it against being switched on again.**

---

The device must be opened, installed and maintained only by qualified personnel (see chap. [1.1 Target Group on p. 5](#)). Make sure to follow the prevailing accident protection regulations when working on conducting systems.

Impermissible modifications and the use of spare parts and components other than those recommended by Stem (see chap. [13.3 Spare Parts on p. 29](#)) may cause injury to persons and damage to technical equipment. Unauthorized personnel must not have any access to the equipment.

Make sure to remove interferences and rectify conditions that may jeopardize safety.

## 4. Scope of Delivery

The scope of delivery is comprised of:

- 1 device cabinet
- 1 set of wall mounting brackets
- 2 batteries (optional)
- this installation manual

To start with, check the original packaging and the unit for damages. Then, check the contents of the package with the items on the delivery slip. In case of damage or questions regarding the scope of delivery, do not hesitate to contact Stem (see chap. [13.2 Manufacturer's Service on p. 28](#)).

## 5.Setup

---



The device can be installed and safely operated both indoors and outdoors.

---

When you select the installation location, observe the following:

- **ATTENTION:** All cables should be laid in a way that the data communication is not interfered with electromagnetic radiation. The appropriate standards for information technology cabling installation (Part 2: EN 50174-2 Installation planning and practices inside buildings and Part 3: EN 50174-3 Installation planning and practices outside buildings) should be taken into account. Stem recommends a minimum distance of 1.0 m between data communication cables and power cables.

- Avoid direct sunlight. The shadow of the modules is a preferred location for installation.
- Make sure that no rainwater is able to run from the modules over the cabinet.
- Keep the cables to the device as short as possible in order to minimize cable loss.
- Keep extra cable length to connect the device.
- Mount the device cabinet vertically with the cable glands at the bottom.
- Use the mounting brackets to mount the device at a sufficiently stable wall or rack.



**Make sure to follow the prevailing safety regulations when working with the device. Non-compliance may endanger persons and technical equipment.**

---



Ensure the protection class IP 66 as defined in the standard EN 60529.

---

Avoid installing the device in high humidity conditions or during rainfall, as humidity might be enclosed in the housing and interfere later during operation or damage the equipment.

By means of the supplied material, mount the cabinet as shown

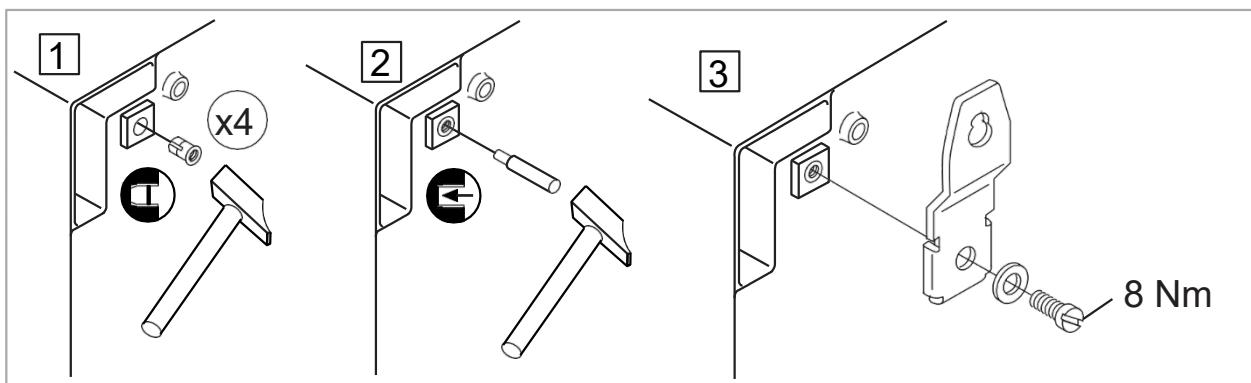

Fig. 1 Wall mounting device cabinet with delivered mounting brackets

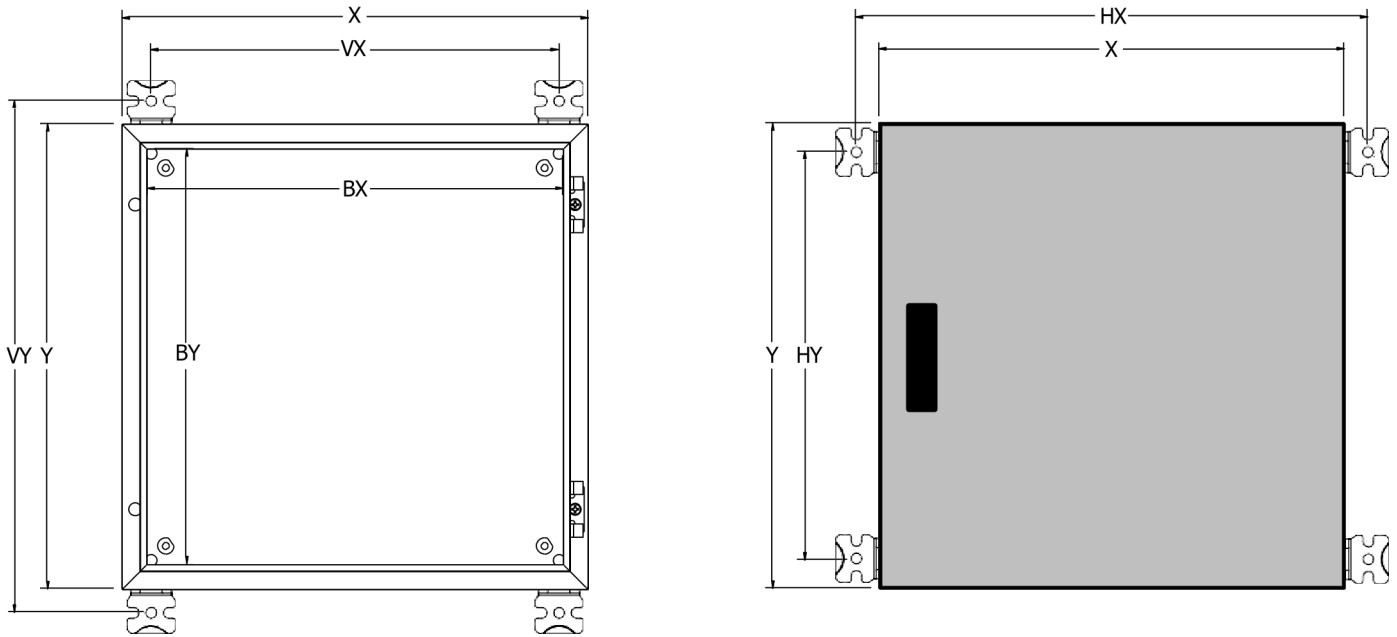

Fig. 2 Dimensions of cabinet and mounting hardware

ENCLOSURE DIMENSIONS (mm)									
PART NO.	EXTERNAL DIMENSIONS			BACKPLATE		VERTICAL BRACKET ORIENTATION SPACING		HORIZONTAL BRACKET ORIENTATION SPACING	
ITEM	X	Y	Z	BX	BY	VX	VY	HX	HY
PMCS-GX	636	847	300	750	550	530	889	664	755
PMCS-GL	436	647	250	350	550	330	689	464	555

## 6. Product Description

The device is sectioned in the following three modules:

- (A) Power supply module (optional)
- (B) Monitoring & Network module / heating and cooling optional
- (C) Connection module

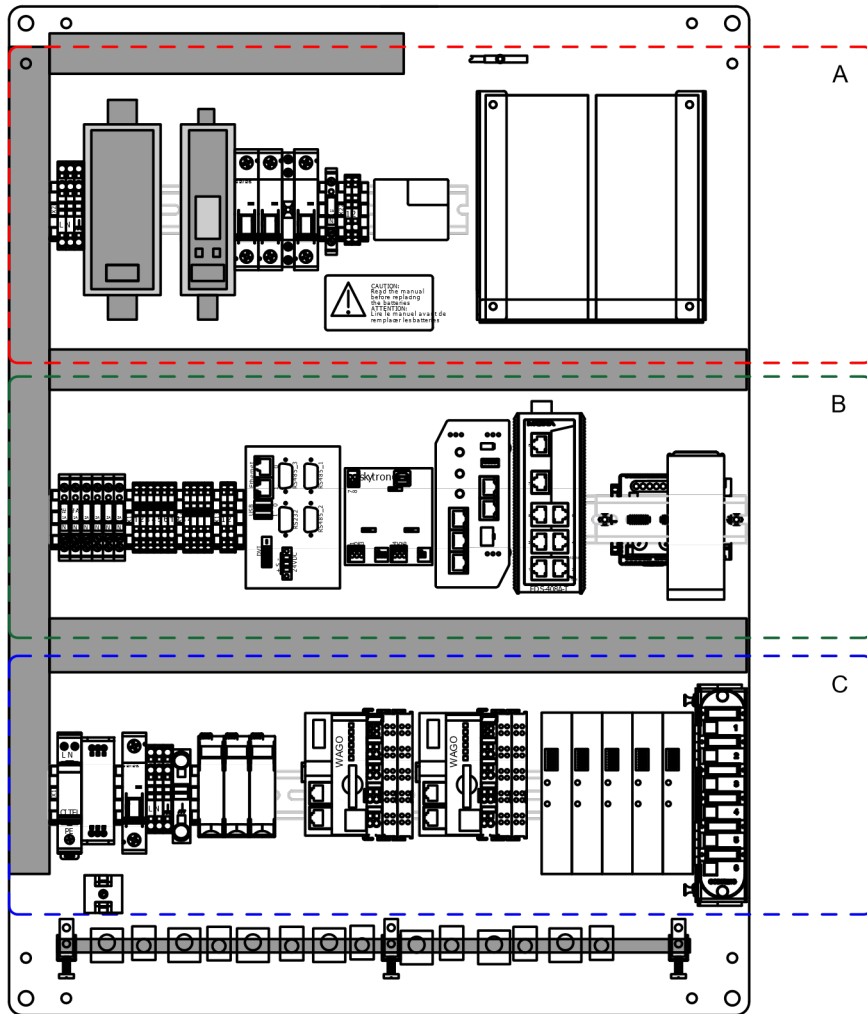

Fig 3 Product overview

## 7. Design



The following pictures refer to a fully developed PowerManager CS. Not all components must be included in your customized product.

## 7.1. Power Supply Module (optional)

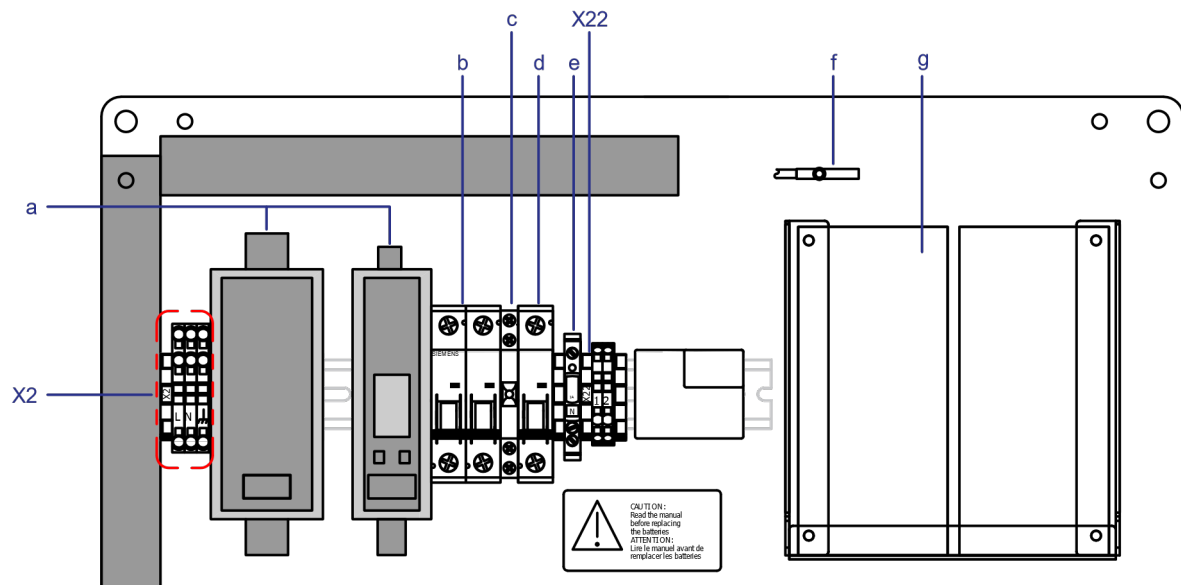

Fig. 4 Power supply module, details

X2	AC terminal
a	24 V DC-UPS
b	Circuit breaker of the battery block
c	Push button to start the device in battery mode
d	AC circuit breaker for heater
e	DC fuse for heater fan
X22	Connection terminal for batteries
f	Battery temperature sensor
g	2 batteries 17Ah

## 7.2. Monitoring & Network Module

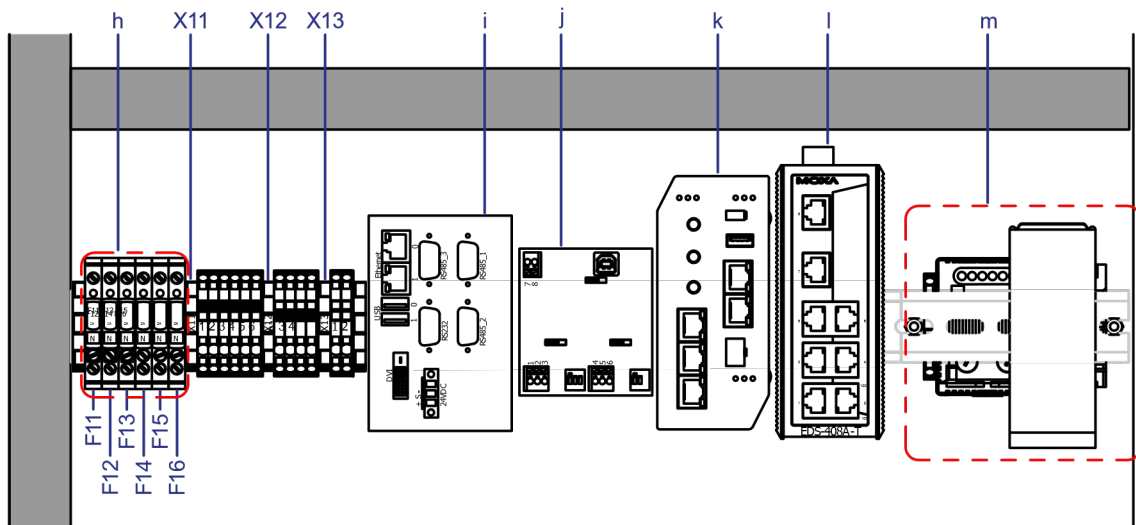

Fig 5 Monitoring & network module, details

h	DC fuses	Fuse assignment
X11	24 V DC buffered for external sensors	F11 Ethernet Switch 1/2
X12	24 V DC unbuffered for sensor heater supply	F12 Router or Ethernet Switch 2 X13
24	24 V DC buffered for monitoring & network components	F13 VDC buffered
	Industry PC(s)	i IPC1/PLC1 j
	USB Converter 2xRS485	F14 IPC2/PLC2
	Router (optional)	F15 k 24 VDC
	Ethernet switch (optional)	F16 unbuffered
		m Heater and two thermostats (optional)

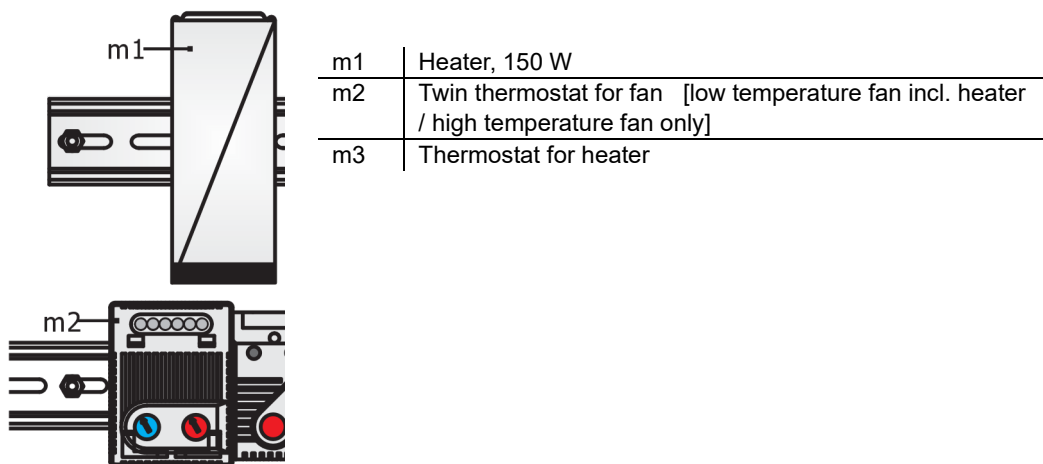

Fig 6. Heating option

### 7.3. Connection Module



**Danger to life! The area marked red in Fig. 8 below is energized.**

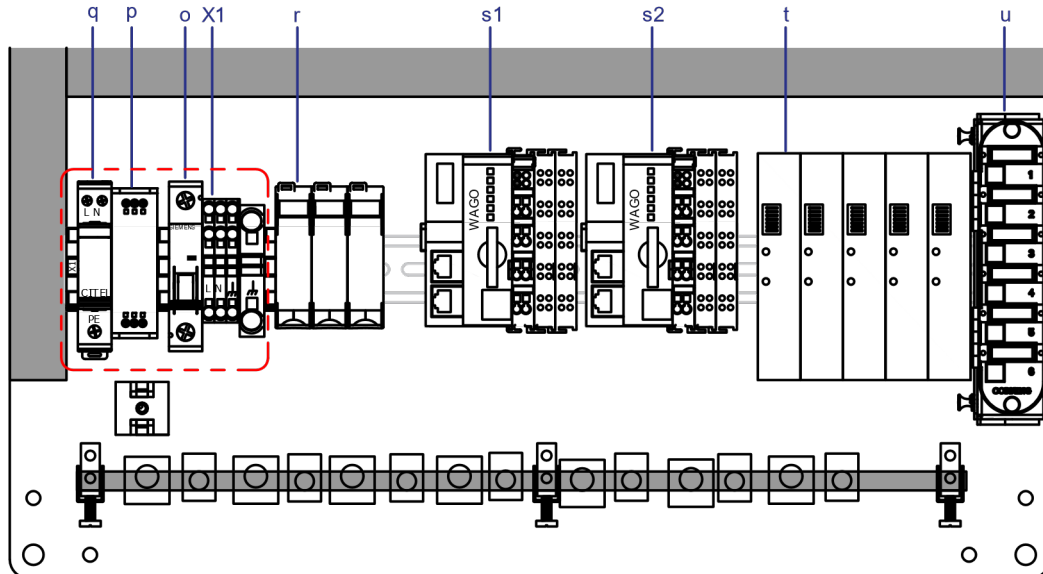

Fig 8 Connection module, details

X1	AC line connection terminal and earth connection PE
o	AC line circuit breaker
p	Mains filter
q	AC line overvoltage arrester
r	Ethernet overvoltage protection devices
s1/s2	PLC
t	RS485 bus and 24 VDC output overvoltage protection devices
u	Splice box

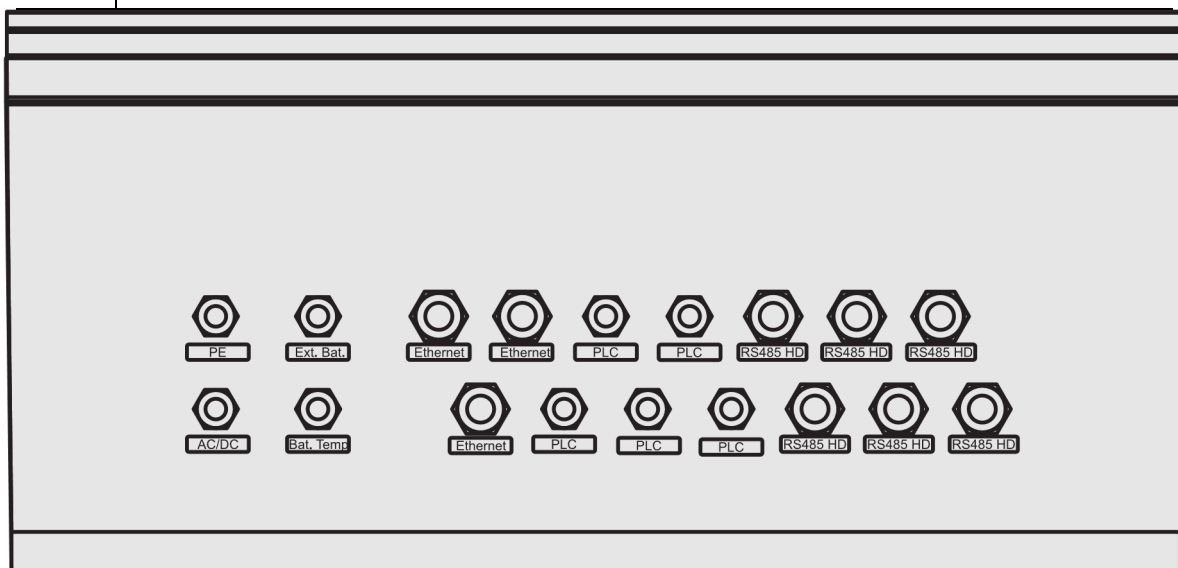

Fig 9 Connectors on the bottom side

## 8. Connection of Data Communication



**Make sure to turn off all fuses and the AC main supply prior to working on the electrical connections of the device.**



**Make sure to mark all cables prior to disconnecting them**

### 8.1. Connecting the Ethernet Cable

1. Lead the Ethernet cable(s) through the cable gland(s) marked ETHERNET ([Fig. 9 on p. 12](#)) into the cabinet.
2. Connect the cable(s) either to the overvoltage arrester(s) (q in [Fig. 8 on p. 12](#)) or to the Ethernet switch (k in [Fig. 5 on p. 11](#)).

### 8.2. Connecting Digital Inputs

Refer to Fig. 10 and Table 1, below, and follow the steps below to connect the digital inputs.

1. Lead the cables through the applicable cable glands ([Fig. 9 on p. 12](#)) into the housing.
2. Tighten the cable gland.
3. Connect the cable shields to the shielding clamps (see [8.12 Connecting the Cable Shield on p. 23](#)).
4. Connect the cables to the connection terminal for digital inputs (Fig. 10 below). Refer to Table 1 below for the correct wire assignment.

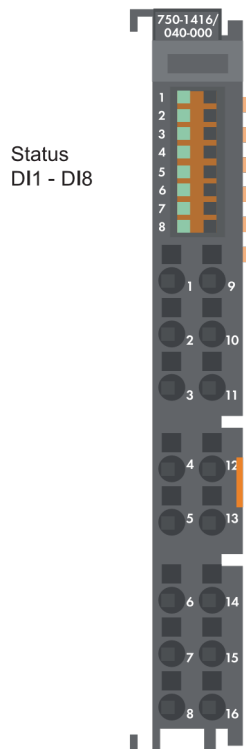

Terminal	Description	Terminal	Description
1	Digital Input 1	9	24 V DC [1]
2	Digital Input 2	10	24 V DC [2]
3	Digital Input 3	11	24 V DC [3]
4	Digital Input 4	12	24 V DC [4]
5	Digital Input 5	13	24 V DC [5]
6	Digital Input 6	14	24 V DC [6]
7	Digital Input 7	15	24 V DC [7]
8	Digital Input 8	16	24 V DC [8]

Table 1 Wire assignment digital input channels

Cross section, solid wire	0.08 mm <sup>2</sup> to 1.5 mm <sup>2</sup> / AWG 28 to 16
Cross section, fine-stranded wire	0.25 mm <sup>2</sup> to 1.5 mm <sup>2</sup> / AWG 22 to 16

Fig 10 8-channel digital input module, 750-1416

### 8.3. Connecting Temperature Sensors

Four-wire sensors can be connected to the RTD module which is based on a three-wire technology.

Refer to Fig. 11 and Table 2, below, and follow the steps below to connect the temperature sensors.

1. Lead the cables through the applicable cable glands ([Fig. 9 on p. 12](#)) into the housing.
2. Tighten the cable gland.
3. Connect the cable shields to the shielding clamps (see [8.12 Connecting the Cable Shield on p. 23](#)).
4. Connect the connection cables to the connection terminal for temperature sensors (Fig. 11 below). Refer to Table 2 below for the correct wire assignment.

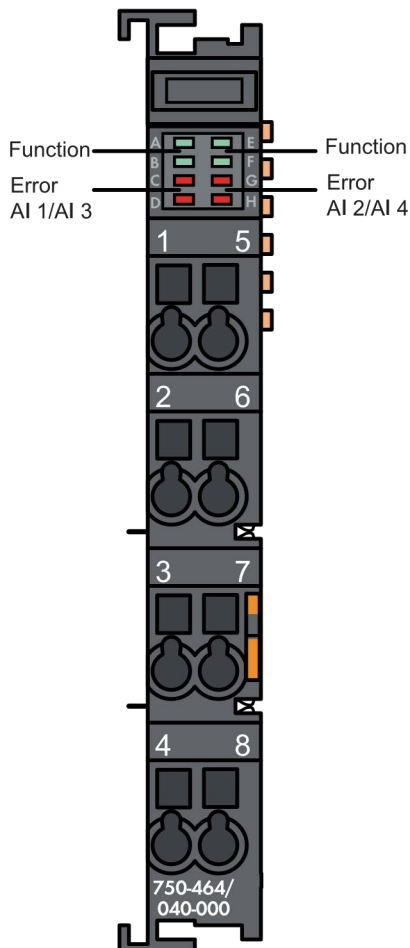

Terminal	Description	Wire Colour
1	supply 1 (+)	white
2	sense 1 (+)	red
3	-	-
4	supply 1 (-) / sense 1 (-)	brown / blue
5	supply 2 (+)	white
6	sense 2 (+)	red
7	-	-
8	supply 2 (-) / sense 2 (-)	brown / blue

Table 2 Wire assignment analog input channels

Cross section, solid wire	0.08 mm <sup>2</sup> to 1.5 mm <sup>2</sup> / AWG 28 to 16
Cross section, fine-stranded wire	0.25 mm <sup>2</sup> to 1.5 mm <sup>2</sup> / AWG 22 to 16

Fig. 11 2-channel analog input module (RTD), 750-464

### 8.4. Connecting Digital Outputs

Refer to Fig. 12 and Table 3, below, and follow the steps below to connect the digital outputs.

1. Lead the cables through the applicable cable glands ([Fig. 9 on p. 12](#)) into the housing.
2. Tighten the cable gland.
3. Connect the cable shields to the shielding clamps (see [8.12 Connecting the Cable Shield on p. 23](#)).
4. Connect the connection cables to the connection terminal for digital outputs (Fig. 12 below). Refer to Table 3 below for the correct wire assignment.

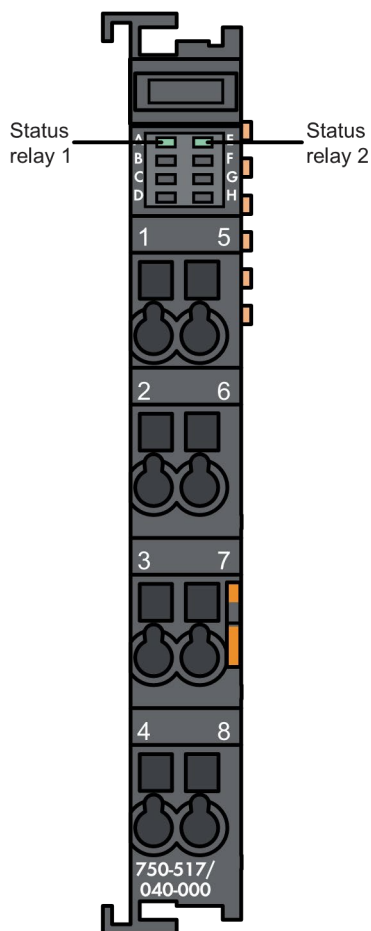

Terminal	Description
1	Digital Output 1 (NO)
2	Digital Output 1 (COM)
3	Digital Output 1 (NC)
4	-
5	Digital Output 2 (NO)
6	Digital Output 2 (COM)
7	Digital Output 2 (NC)
8	-

Table 3 Wire assignment digital output channels

Wire cross section | 0.08 mm<sup>2</sup> to 2.5 mm<sup>2</sup> / AWG 28 to 14

Fig. 12 2-channel digital output module (relay), 750-517

## 8.5. Connecting Analog Inputs

Refer to Fig. 13 and Table 4, below, and follow the steps below to connect the analog inputs.

1. Lead the cables through the applicable cable glands ([Fig. 9 on p. 12](#)) into the housing.
2. Tighten the cable gland.
3. Connect the cable shields to the shielding clamps (see [8.12 Connecting the Cable Shield on p. 23](#)).
4. Connect the connection cables to the connection terminal for analog inputs (Fig. 13 below). Refer to Table 4 below for the correct wire assignment.

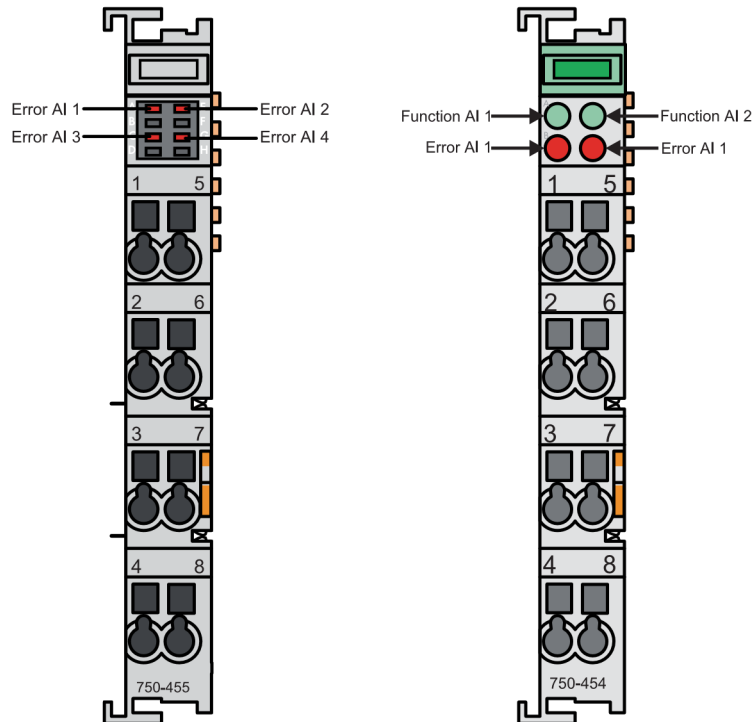

Fig. 13 left: 4-channel analog input module, right: 2-channel analog input module

4 channel analog input (750-455)		2 channel analog input (750-454 / 750-466)	
Terminal	Description	Terminal	Description
1	Analog Input 1 (0/4-20 mA)	1	Analog Input 1 (0/4-20 mA)
2	GND (common)	2	24 VDC (common)
3	Analog Input 3 (0/4-20 mA)	3	GND (common)
4	GND (common)	4	shield
5	Analog Input 2 (0/4-20 mA)	5	Analog Input 2 (0/4-20 mA)
6	GND (common)	6	24 VDC (common)
7	Analog Input 4 (0/4-20 mA)	7	GND (common)
8	GND (common)	8	shield

Table 4 Wire assignment analog input channels

Wire cross section | 0.08 mm<sup>2</sup> to 2.5 mm<sup>2</sup> / AWG 28 to 14

## 8.6. Connecting Analog Outputs

1. Lead the cables through the applicable cable glands ([Fig. 9 on p. 12](#)) into the housing.
2. Tighten the cable gland.
3. Connect the cable shields to the shielding clamps (see [8.12 Connecting the Cable Shield on p. 23](#)).
4. Connect the connection cables to the connection terminal for analog outputs (Table 5 and Fig. 14 below).

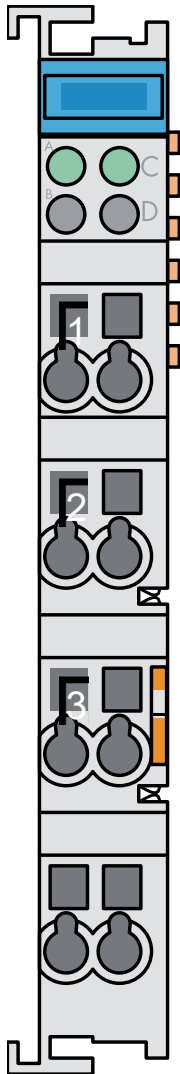

Terminal	Description
1	Analog Output 1 (0 or 4-20 mA)
2	24 V DC (common)
3	GND (common)
4	cable shield
5	Analog Output 2 (0 or 4-20 mA)
6	24 V DC (common)
7	GND (common)
8	cable shield

Table 5 Wire assignment analog output channels

Wire cross section | 0.08 mm<sup>2</sup> to 2.5 mm<sup>2</sup> / AWG 28 to 14

Fig. 14 2-channel analog output module

## 8.7. Connecting S0-Interface (counter)

1. Lead the connection cables through the applicable cable gland ([Fig. 9 on p. 12](#)) into the housing.
2. Tighten the cable gland.
3. Connect the cable shields to the shielding clamps (see [8.12 Connecting the Cable Shield on p. 23](#)).
4. Connect the connection cables to the connection terminal for S0 interface (Fig. 15 below). Refer to Table 6 below for the correct wire assignment.



Make sure that terminal 3 is connected to terminal 4, and terminal 7 is

connected to terminal 8.

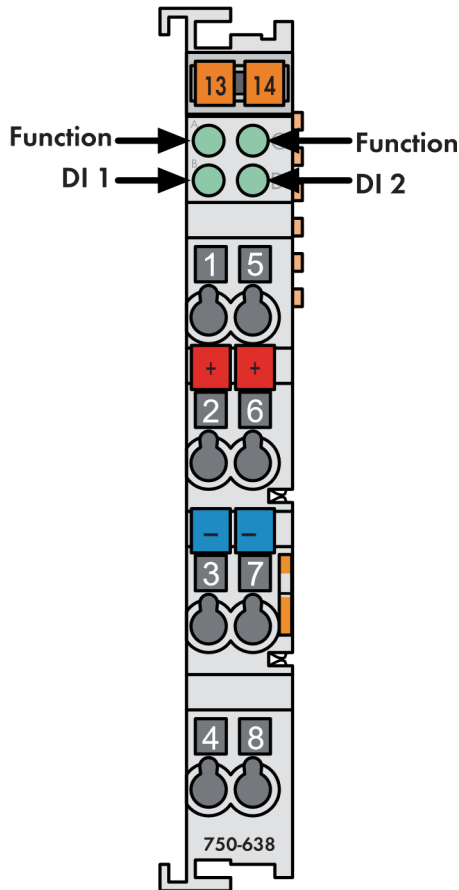

Terminal	Description
1	channel 1 (-)
2	channel 1 (+)
3	-
4	-
5	channel 2 (-)
6	channel 2 (+)
7	-
8	-

Table 6 Wire assignment 2 channel counter interface

Wire cross section | 0.08 mm<sup>2</sup> to 2.5 mm<sup>2</sup> / AWG 28 to 14

Fig. 15 2-channel counter module, 750-638

## 8.8. Connecting RS485 Bus Devices

Stem recommends that you use cable type Li2YCYv (TP) 4 x 2 x 0.5.

1. Lead the connection cables through the cable gland marked *RS485 HD* ([Fig. 9 on p. 12](#)) into the housing.
2. Tighten the cable gland.
3. Connect the cable shields to the shielding clamps (see [8.12 Connecting the Cable Shield on p. 23](#)).
4. Unplug X4 and X5 from the fieldbus overvoltage protection device.
5. Connect the connection cables to the plugs of the fieldbus overvoltage protection device (Fig. 16 below). Refer to Table 7 below for the correct wire assignment.

6. Plug the connectors X4 and X5 to the fieldbus overvoltage protection device.



Fig 16 Preparing connectors X4 and X5

 If included with pyranometer shipment, the Hukseflux "Pyranometer Insulation Disc" should be installed per manufacturer's provided recommendations.

Fig 17 Fieldbus overvoltage protection device

A: Metal foot catch, pull to remove



	Terminal	4.1	4.2	4.3	4.4	6.1	6.2	6.3	6.4
		5.1	5.2	5.3	5.4				
	Description	D- (B)	GND	COM	D+ (A)	GND	24V	GND	24V
Li2YCYv(TP4x2x0.5)	wire color	Yellow	bridge		Green	Brown	White	Blue/Grey	Red/Rose
S0Z-03D		Blue	bridge		White	Black	Brown	-	-
Lufft Met Station		Yellow	bridge		Green	White	Brown	Blue/Grey	Red
SR05		Grey	-	Blue	White	Black	Brown	-	-
SR30-M2-D1*		Grey	-	Blue	White	Black	Brown	-	-
RT1		Grey	-	Green	Yellow	Blue	Red	-	-
IMT		Orange	bridge		Brown	Black	Red	-	-

\*Applies only to SR30-M2-D1 model. Consult manufacturer documentation for all other models.

Table 7 Wire assignment RS485 bus devices

### Assignment of the serial overvoltage protection modules

The Fieldbus overvoltage protection devices are assigned as follows:

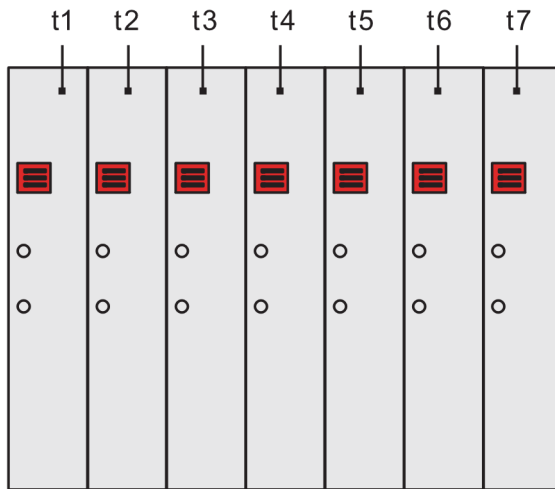

Fig 18 Serial overvoltage protection assignment

Device	DC Power Supply	Target Devices
t1	Unbuffered 24 V DC	Lufft weather station (heated) or inverters
t2 to t7	Buffered 24 V DC	Sensors without heating or inverters

## 8.9. Terminating the RS485 Bus

If the device is the last participant in the RS485 Bus line, make sure that the dip switch 1 on the Fieldbus overvoltage protection device is in *ON* position (see Fig. 19 below). If necessary, put the dip switches 2 and 3 in *ON* position to enable the BIAS.

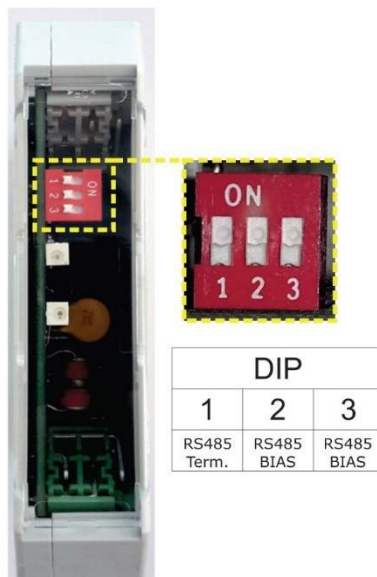

Fig 19 Terminating RS485 bus

## 8.10. Commissioning the Router



Make sure the router is de-energized before you insert the SIM card.



Make sure to mark all cables prior to disconnecting them.

1. Disconnect all cables from the router.
2. Carefully remove the router from the DIN rail (refer to Fig. 20 below).
3. Insert the SIM card into the SIM card slot (refer to Fig. 21 below).
4. Put the Router at an angle of approx. 45 ° with the bottom part of the mounting rail on the DIN rail (refer to Fig. 20 below).
5. Carefully press the top side of the mounting rail on the DIN rail until the bracket clicks.
6. Reconnect all cables to the router.
7. Connect the antenna to the antenna socket of the router.  
If it is necessary to position the antenna outside the cabinet, lead the antenna cable through an applicable cable gland into the cabinet and connect it to router and antenna.
8. Connect the plug of the antenna cable to the socket marked ANT (yellow frame in Fig. 22 below) on the router.
9. If necessary, attach the antenna cable at an appropriate position inside the cabinet.

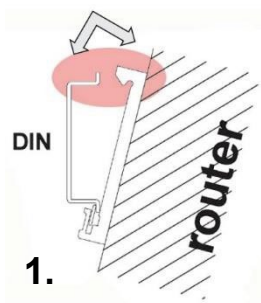

1.

Fig. 20 Router mounting

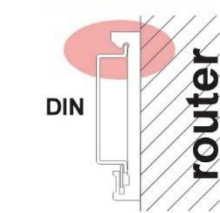

2.

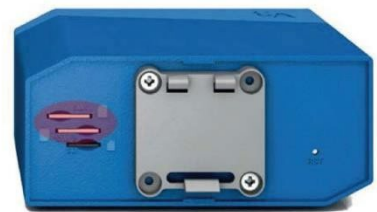
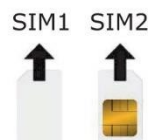

Fig. 21 S M card slots on the router's back side

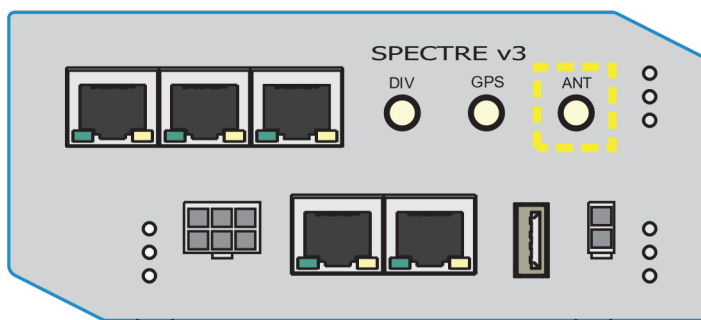

Fig. 22 Antenna socket (arked yellow) on the router's front side

## 8.11. Commissioning the VPN-Router

The network connection can be established for the following two use cases:

A: Stem devices (2) and customers router (1) in the same network (refer to Fig. 23 below).

B: Stem devices (2) and customers router(1) in two different networks (refer to Fig. 24 below).

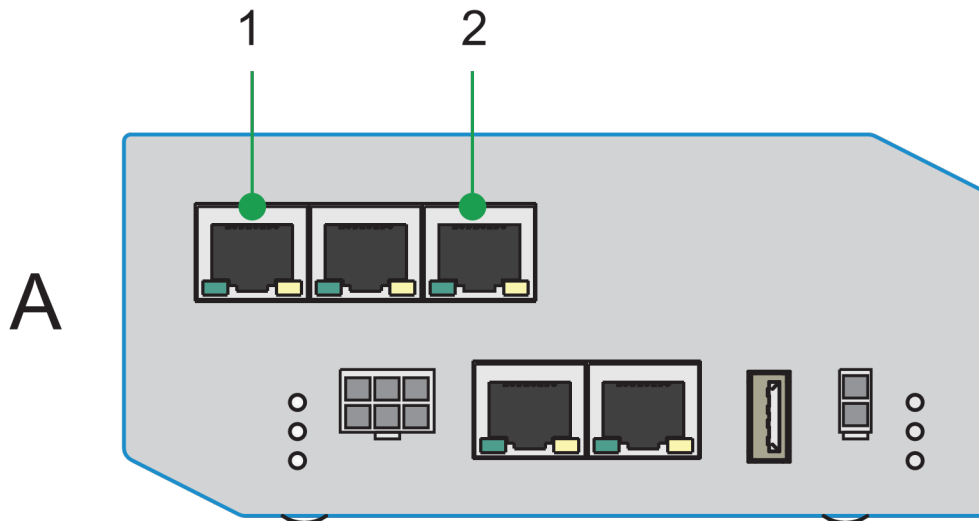

Fig. 23 Connecting the VPN-router, case A

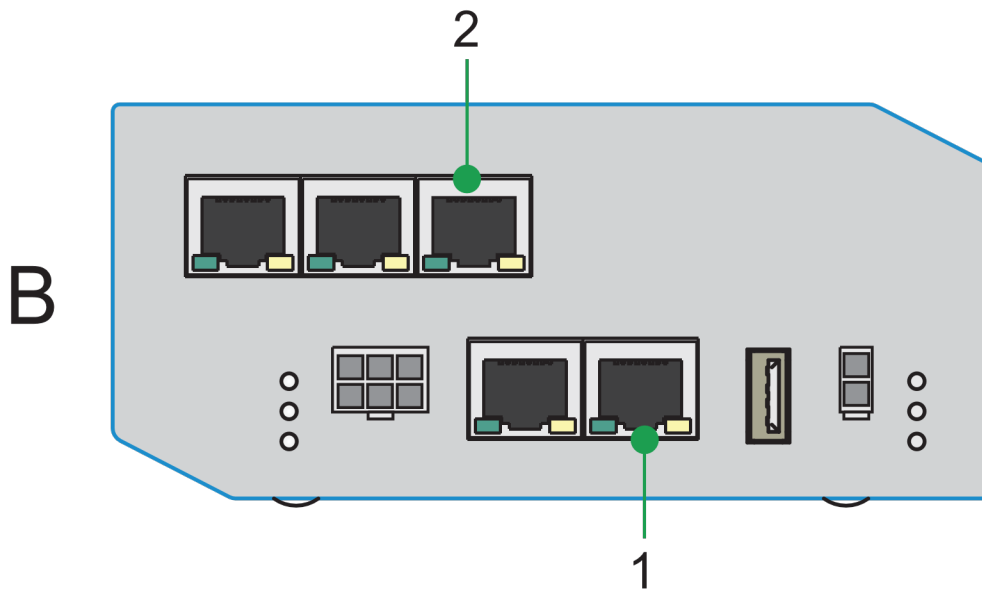

Fig. 24 Connecting the VPN-router, case B

## 8.12. Connecting the Cable Shield

When you connect the cable shield, follow the steps below:

1. Unspool a sufficient length of the cable.
2. Pull the shielding over the cable.
3. Lead the cable through the applicable shielding clamp.
4. Attach the cable using the shield securing clip (left in Fig. 25 below), or using the spring-type terminal (right in Fig. 25 below).

Fasten the shield securing clip by hand, do not use a screwdriver or forceps (left in Fig. 25 below).

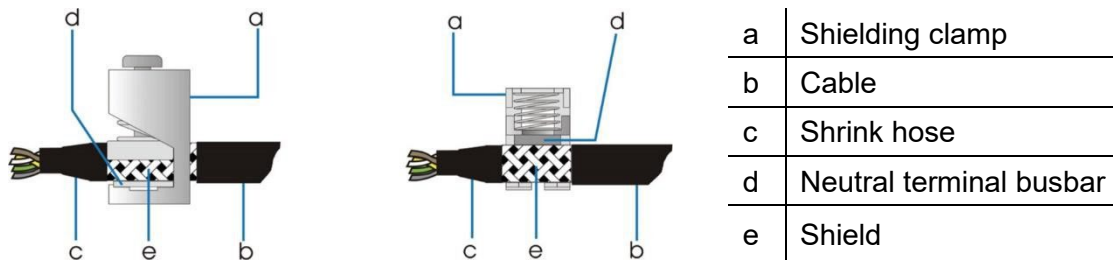

Fig 25 Left: Shield over cable, hand-fasten shield securing clip Right: Shield over cable, spring-type terminal

### 8.13. Splice Box - Removal and Installation

Make sure not to bend the fibre-optic cables as this may cause irreparable damage.

Follow the steps below to remove the splice box:

1. Push the disconnect tab.
2. Lift the splice box a little and pull it upwards to remove it from the DIN rail.



Fig. 26 Splice box

3. After splicing the fibre optic cables, install the splice box in reverse order.

### Fibre-Optic PowerManager CS Network

Fig. 27 below shows an example of how to link several devices in a fibre-optic network; as a line or as a ring.



We recommend the ring structure which is redundant. If one station would be out of order all other stations could still communicate.

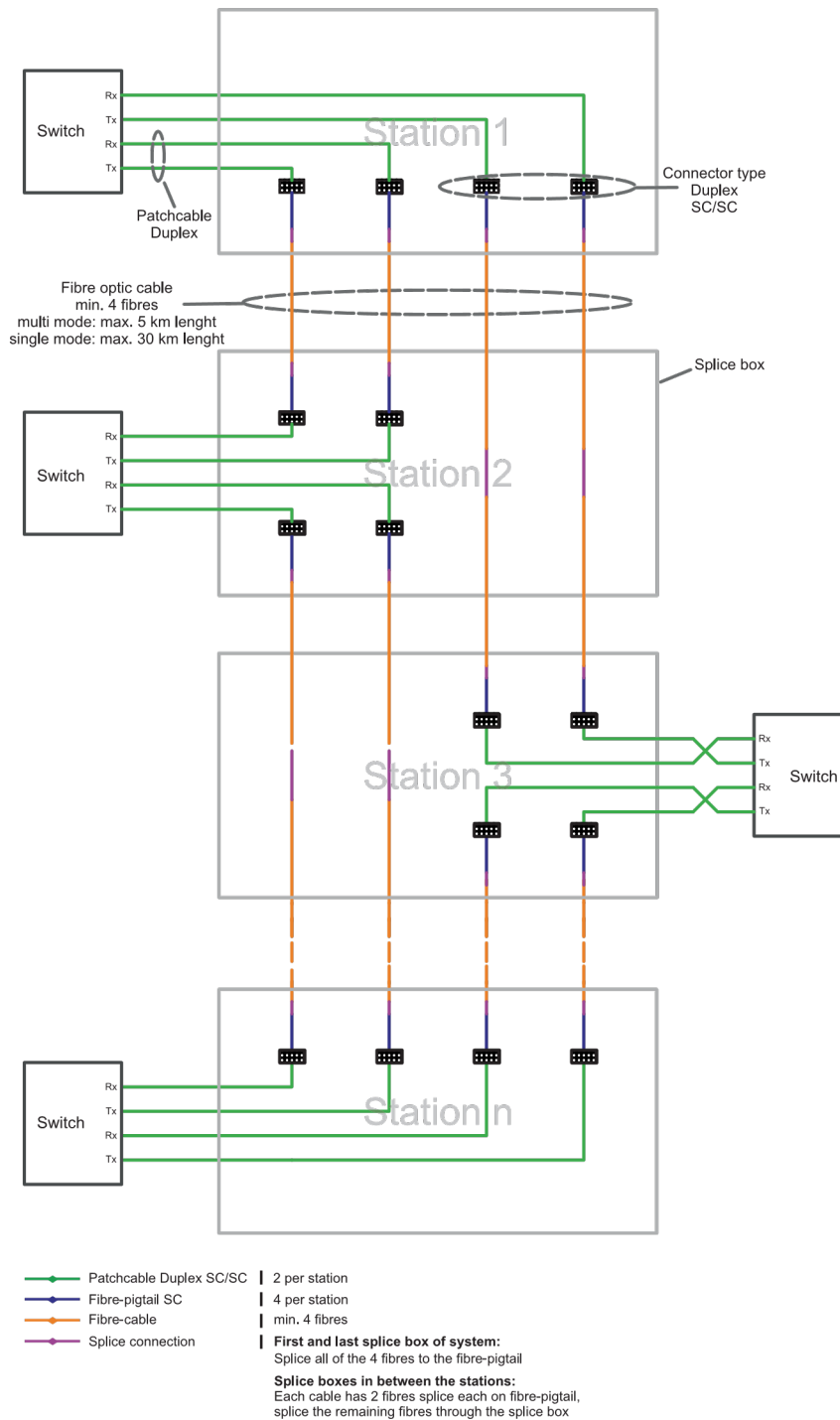

Fig 27 Fibre-optic network topology

## 9. Connecting Power Supply



**Danger! Make sure to turn off all fuses and the AC main supply prior to working on the electrical connections.**

### 9.1. Installing and Connecting the Batteries



**When installing the batteries, ensure the correct polarity and observe the safety instructions on the batteries.**

The batteries are not pre-installed within the device when shipped.

To connect the batteries refer to Fig. 28 below and follow the steps below:



Make sure the *plus* pole of the first battery is located next to the *minus* pole of the second.



If necessary, clean the contact surfaces and slightly apply pole grease

1. Put the circuit breaker of the battery block (b in [Fig. 4 on p. 10](#)) into *off* position.
2. Connect the batteries using the battery-pole connector (b in Fig. 28 below), the pole screw nuts and the protective covers on the poles.



Apply a torque of 2.5 Nm/1.84 lb ft.

3. Position the batteries onto the battery holder with their connectors facing each other.
4. Lead the protection covers over the connection cables.
5. Connect the red cable to the *plus* pole of the first battery.
6. Connect the black cable to the *minus* pole of the second battery.
7. Attach the pole protecting covers.

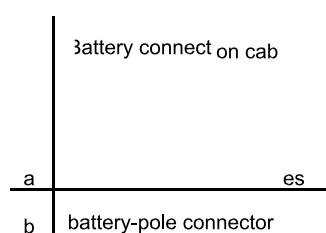
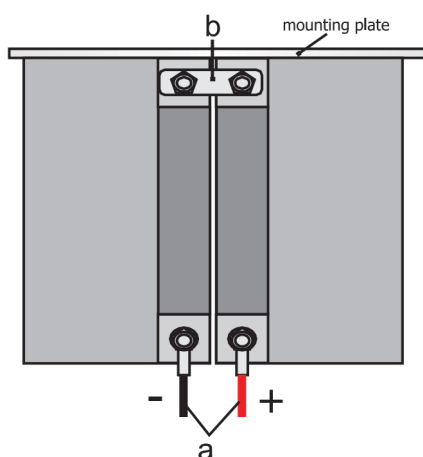

Fig. 28 Batteries top view

The batteries are automatically loaded through the DC UPS as soon as the device has started operating and the battery circuit breaker has been switched on.

## 9.2. Connecting the Earthing Cable

Lead the earthing cable through the cable gland marked *PE* and connect it to the earthing connector above the cable gland. Fig. 29 and Table 8, below, show how to connect this cable as well as its wire cross-section.

## 9.3. Connecting the AC Main Cable

Lead the AC main cable through the cable gland marked *AC*. Fig. 29 and Table 8 below show how to connect this cable as well as its wire cross-section.

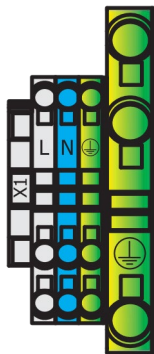

Terminal X1	Wire colour	Description
L	Black	Phase, H07V-K 2.5 mm <sup>2</sup>
N	Blue	Neutral, H07V-K 2.5 mm <sup>2</sup>
PE	Green/yellow	PE, H07V-K 2.5 mm <sup>2</sup>
PE	Green/yellow	Earthing cable H07V-K 16 mm <sup>2</sup>

Table 8 Terminal X1 assignment

Fig 29 AC terminal block X1

## 10. Energize / De-Energize



The areas marked red in [Fig. 4 on p. 10](#) and [Fig. 8 on p. 12](#) are energized with AC voltage.

To energise the device, make sure to

- put the AC line circuit breaker (m in [Fig. 8 on p. 12](#)) in on position
- put the circuit breaker of the battery block (b in [Fig. 4 on p. 10](#)) in on position.
- put all DC fuses (h in [Fig. 5 on p. 11](#)) in on position. To de-energise the device,

make sure to

- put the AC line circuit breaker (m in [Fig. 8 on p. 12](#)) in off position
- put the circuit breaker of the battery block (b in [Fig. 4 on p. 10](#)) in off position.

## 11. Connecting External Battery Box

To increase the back-up time, it is possible to connect a battery box with two 40 Ah batteries.

 No internal batteries must be connected when using the external battery cabinet.

 If not already installed, install the self-adhesive rain protection as described in [5 Setup on p. 7](#).

To connect the battery box follow the steps below:

1. Bring the circuit breaker of the battery block (b in [Fig. 4 on p. 10](#)) into *off* position.
2. Position the batteries onto the battery holders with their connectors facing to the left side.
3. Connect the red cable to the *plus* pole of the first battery.
4. Connect the minus pole of the first battery with the plus pole of the second battery using the delivered black battery-pole connector cable and pole screw nuts.
5. Connect the black cable to the *minus* pole of the second battery.

 Apply a torque of 5 Nm/3.68 lb ft.

6. Attach the pole protecting covers.
7. Lead the delivered connection cable through the applicable cable gland into the housing.
8. Connect the wires to the terminal X22 (refer to [Fig. 4 on p. 10](#)).
9. Lead the other end of the connection cable into the battery box.
10. Connect the wires to the terminal as shown in Fig. 30 below.

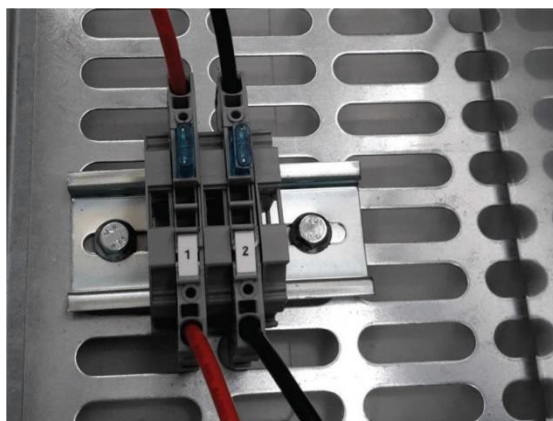

Terminal	Description
1	red (+)
2	black (-)

Fig 30 Connecting external battery box

## 12. Mounting Pyranometers/Reference Cells

### 12.1. Sensor Mounting Plate

Also nergy's mounting plate is also shipped with every pyrometer purchased. This design accommodates several different sensors and can be mounted in vertical or horizontal orientations. The below directions will walk you through typical installation.



Fig 31 Mounted tangential to pole



Fig 32 Mounted parallel to pole

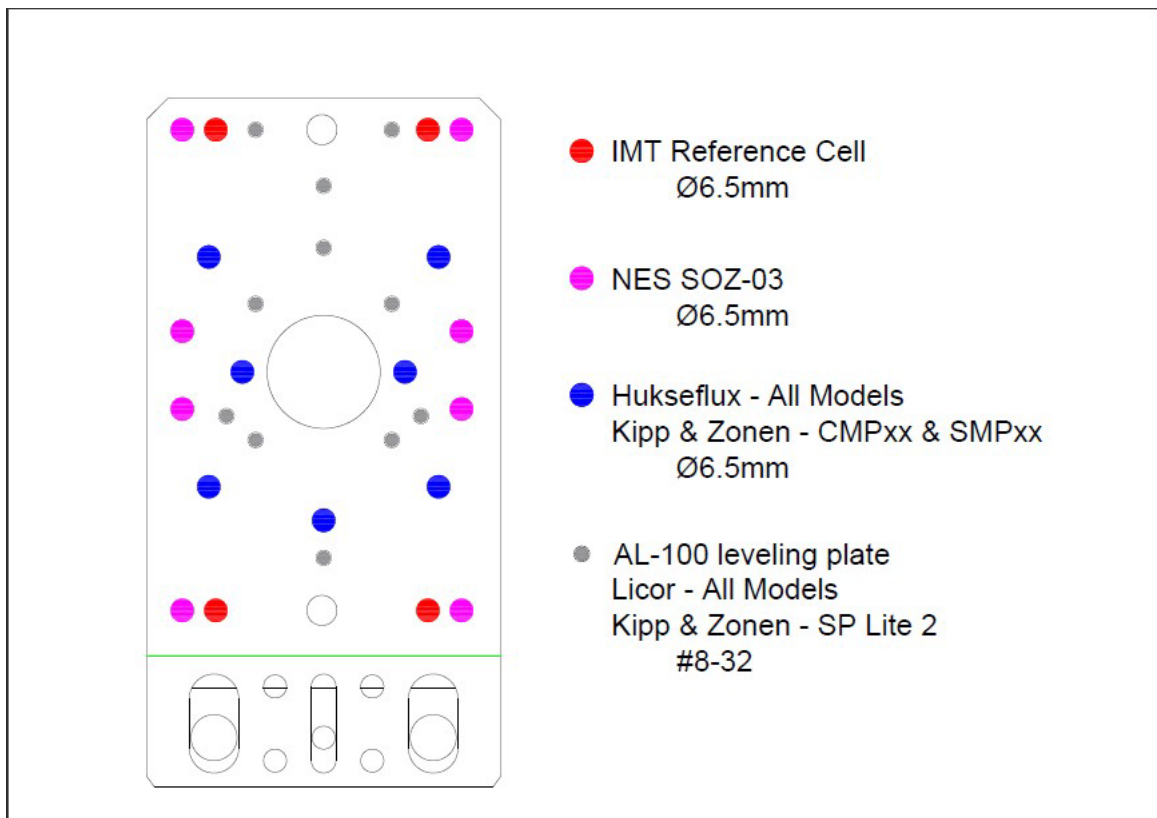

Fig 33 Mounted holes for select pyrometers and sensors

## 12.2. Mounting the Sensor Mounting Plate

The Sensor Mounting Plate will be horizontal to whatever it is mounted to - be that an upright pole or a pole that is oriented to the plane or array. Mounting directions are as follows:

If not mounted yet, mount the pyranometer on the mounting plate (chap. 12.3 Mounting a Pyranometer on p. 41).



Make sure that the installed sensors are not shaded by solar modules, support constructions or other installations.

1. Choose the desired orientation, using surface (a) or (b)
2. Put the sensor mounting plate [1] and plastic saddle [2] (if applicable) in position.
3. Lead the U-bolt [2] through the corresponding drilled holes.
4. Place the two washers [3], two split lock washers [4] and two nuts [2] onto the screws.
5. Three pan head screws are provided for sensor mounting if needed.
6. Attach and level the sensor per provided directions below and the sensor manufacturer's directions.

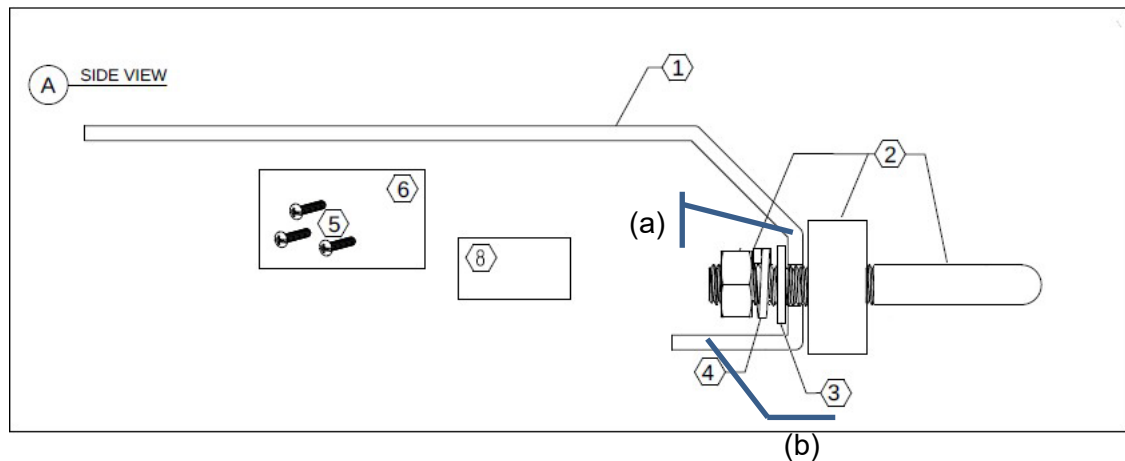

BILL OF MATERIALS		
REF.	QTY.	DESCRIPTION
①	1	FABRICATED 12GA PLATED STEEL BRACKET
②	1	ZINC-PLATED STEEL CLAMPING U-BOLT, M10 THREAD SIZE, 2-1/16" ID WITH PLASTIC SADDLE HTTPS://WWW.MCMMASTER.COM/3066T34/ OR EQUIVALENT
③	2	18-8 STAINLESS STEEL WASHER FOR M10 SCREW SIZE, 10.5 mm ID, 20 mm OD HTTPS://WWW.MCMMASTER.COM/93475A280/ OR EQUIVALENT
④	2	18-8 STAINLESS STEEL SPLIT LOCK WASHER FOR M10 SCREW SIZE, STANDARD, 10.7mm ID, 18.1mm OD, HTTPS://WWW.MCMMASTER.COM/92148A210/ OR EQUIVALENT
⑤	3	PAN HEAD COMBINATION PHILLIPS/SLOTTED SCREWS, 18-8 STAINLESS STEEL 8-32 THREAD SIZE, 3/4" LONG, HTTPS://WWW.MCMMASTER.COM/90604A197/ OR EQUIVALENT
⑥	1	BAG FOR (3) SCREWS (P/N TBD)
⑦	1	BAG FOR ASSEMBLY WITH LABEL - OVERALL SIZE 262x100x59mm (LxWxH) (P/N TBD)
⑧	1	WHITE LABEL WITH TEXT "AlsoEnergy WS-BR-PY4A" (CAN BE TWO LINE TEXT) (P/N TBD)

Fig 34 Sensor Mounting Plate side view with bill of material

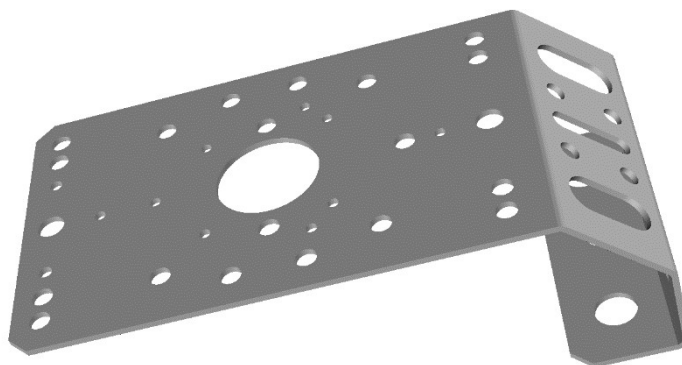

Fig 35 Sensor Mounting Plate

### 12.3. Mounting a Pyranometer

To mount a pyranometer, refer to Fig. 36 on p. 41 and follow the steps below:



lease also consider the manufacturer's manual when you mount the reference cell.

---



Make sure to connect no other pyranometer than the unit determined by the PowerManager CS® configuration. Refer to the calibration sheet attached for the allocation.

---

1. If necessary, loosen the four screws (f in Fig. 36 on p. 41).
2. Remove the sun shield from the pyranometer.
3. Place the pyranometer (c in Fig. 36 on p. 41) in position on the mounting plate, either horizontally or in the plane of the array.
4. Put the two screws (b) that will attach the pyranometer to the mounting plate through the holes of the mounting plate and the pyranometer.
5. Tighten the screws to the specified torque.
6. Carefully press the sun shield onto the pyranometer until it clicks into place.
7. If necessary, re-fasten the four screws (f).
8. Make a cable loop for strain relief of the connection cable and lead the cable from the mounting device to a fixed component such as the array mounting frame.
9. Fasten the cable there. This way, the cable cannot vibrate.
10. Connect the pyranometer cable.

a	Sun screen
b	Screws
c	Pyranometer
d	Washers (optional)
e	Nuts (optional)
f	Screws (optional)

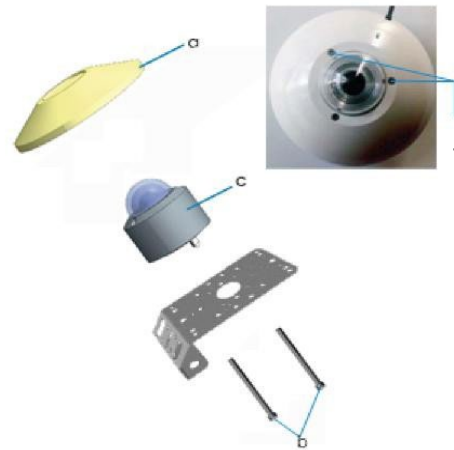

Fig. 36 Pyranometer on mounting device with screws, b, inserted from below

## 12.4. Mounting a Reference Cell

To mount the silicon reference cell, refer to Fig. 37 on p. 42 and follow the steps below:



Please also consider the manufacturer's manual when you mount the reference cell.

---



Make sure to connect no other reference cell than the unit determined by the PowerManager CS® configuration.

---

1. Remove the screws (c in Fig. 37 on p. 42) from the sensor cap (b).
2. Carefully remove the sensor cap from the housing (a).
3. Put the housing in position on the mounting device (in the module plane or horizontal)
4. Lead the four screws through the housing and the mounting device.
5. Screw the nuts onto the four screws, and tighten the nuts.
6. Put the sensor cap (b) in position on the housing and install the screws (c).
7. Make a cable loop for strain relief of the connection cable and lead the cable from the mounting device to the surrounding fixed construction.
8. Fasten the cable there. This way, the cable cannot vibrate.
9. Connect the reference cell.

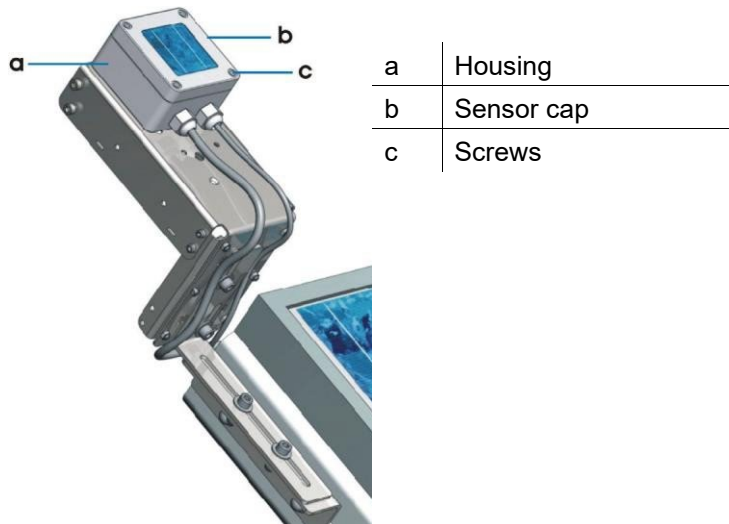

Fig. 37 Reference cell on mounting device

## 13. Starting up

### 13.1. Checking the Connections

1. Make sure to check all plug and screw connections for firm attachment.
2. Measure the earthing resistance to ensure proper earthing.
3. Check if the AC supply is connected.
4. Check if all circuit breakers are closed.
5. Check if the power supply (batteries) is properly connected.

### 13.2. Starting the Data Communication

The data communication is set up by personnel from Stem or by personnel trained by Stem.

### 13.3. Starting the Device in Battery Mode

You can start the device in battery mode if there is no AC power supply available. To do so, press the push-button marked c in [Fig. 4 on p. 10](#).

To switch off the device, put the circuit breaker of the battery block (*b* in [Fig. 4 on p. 10](#)) in *off* position.

## 14. Maintenance

### 14.1. User Maintenance

The device and its components must not be maintained and repaired by anyone other than personnel of the manufacturer Stem or personnel trained and authorized by Stem using original parts.

## 14.2. Manufacturer's Service

Do not hesitate to contact Stem for information and requests.

### Stem EMEA region hotline:

service	+49 (0) 30 338 430-100
---------	------------------------

### email Stem support:

[service@alsoenergy.com](mailto:service@alsoenergy.com)

### 14.3. Spare Parts

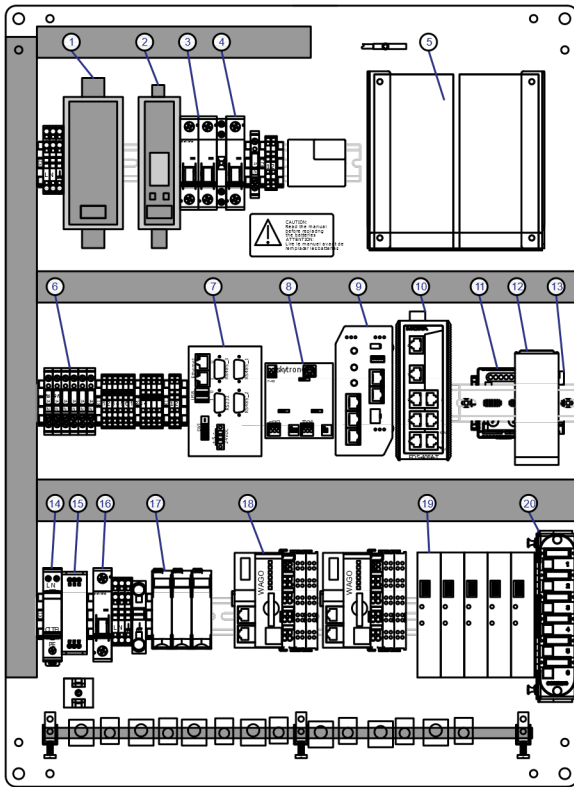

Fig. 28  
Spare parts

	Spare Part	Order No.
1	Power supply unit	PVSE 230/24-10
2	UPS	PVUA 24/24-10
3	Circuit breaker 2-pole, B, 10 A	5SY6210-6
4	Circuit breaker 1-pole, B, 6A	5SY6106-6
5	Battery set, 12 V, 17 Ah, AGM	12FGL17
6	DC fuse 1 A	1180-01-1A
6	DC fuse 2 A	1180-01-2A
6	DC fuse 3 A	1180-01-3A
7	IPC with skytron firmware	CH-E0-PMCE
7	Cfast card 8GB, with skytron firmware	CFAST8GPMCE
8	USB-2x485 converter	ET-CV-USB
9	Router LTE EU	BB-SR30300111
9	LAN Router	ET-LCS-VPN
10	Switch 408 MM	ET-MM-2SC6
10	Switch 408 SS	ET-MS-2SC6
10	Switch 405 MM	ET-MM-2SC3
10	Switch 405 SS	ET-MS-2SC3
10	Switch co 408	ET-MW-08
11	double thermostat	01146.9-00
12	Heater	C40/2-150W24V-AC-240V-11-1-0
13	Thermostat	01146.9-00
14	AC surge protector	DS240S-230
15	EMC filter	2794110
16	Circuit breaker 1-pole, B, 10A	5SY6110-6
17	ETH overvoltage protector	OVP-ETH
18	Fieldbus coupler / PLC	<a href="#">see Table 9 on p. 35</a>
19	RS485 bus interface	OVP-CE-R2P1
20	Splice box cabinet	565661
20	multimode adapter	255257
20	single mode adapter	CCH-CP12-59
20	DIN rail bracket	DIN-MNT30

PLC device	Material name	Order No.
Fieldbus coupler Ethernet	750-352/040-000	SA-WFC-G3
Fieldbus supply 24V	750-602/025-000	750-602/025-000
Fieldbus controller Ethernet (1 MB)	750-880/025-000	SA-WFC-P1
Fieldbus controller Ethernet (64 MB)	750-8202/025-001	SA-WFC-P64
Serial interface RS-232/RS-485 (T)	750-652/025-000	IO-W652-1S
2 x S0 counter	750-638/025-000	IO-W638-2C
2 channel analog input (RTD)	750-464/040-000	IO-W464-4AT
8 channel digital input	750-1416/040-000	IO-W1416-8D24

4 channel analog input	750-455/025-000	IO-W455-4AL
2 channel analog input	750-466/025-000	IO-W466-2AL
4 channel analog input, DC $\pm 10$ V	750-457/025-000	IO-W457-4A10
2 channel analog output	750-554/025-000	IO-W554-2ALO
2 channel analog input (differential input)	750-454/025-000	IO-W454-2AL
2 channel digital output	750-517/040-000	IO-W517-2R
Bus termination clamp	750-600/025-000	750-600/025-000

Table 9 Fieldbus coupler / PLC spare parts

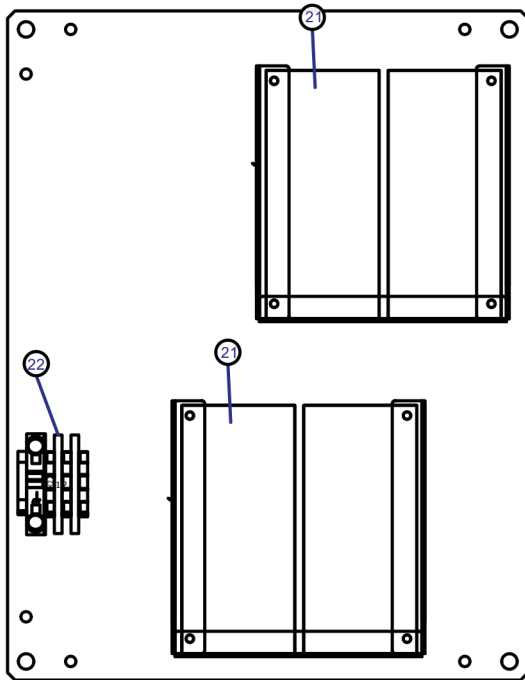

Fig. 30 Spare parts, 40 Ah battery option

	Spare Part	Order No.
21	Battery 12 V, 40 Ah, AGM	12FGL42
22	Blade type fuse 15A (mini)	0297010.U

## 15. Liability

Stem is not liable for damages resulting from unintended use of the technical equipment or from non-compliance to the regulations. Intended use applies to the following conditions:

- The safety regulations laid down in this installation manual are followed.
- Installation and maintenance work is carried out only by qualified and authorised personnel.
- The general prevailing accident protection regulations are followed.
- Attention is paid to the technical data of the equipment.

- The safety regulations given by the manufacturer of the inverter are followed.
- The general, locally prevailing installation regulations are followed.

---

⚠ Any liability and warranty claims will become invalid if the installation regulations have not been followed and observed!

---

⚠ When you open the equipment and/or perform any repairs or changes on your own, Stem is not responsible for specified performance and operational safety. All provisions of the guarantee and duties of Stem are forfeited.

---

## 16. Technical Data

### Components

Hardware	
1 DC UPS	24 V DC
2 Batteries	AGM 12 V, 17 Ah, default optional: external battery box with two AGM 12 V, 40 Ah batteries
Up to 2 Industry PCs	Compact Flash up to 2 GB, battery-backed clock
Up to 2 Ethernet switches	fibre-optic network
1 Router	LTE or VPN
Up to 2 fieldbus coupler/controller	Fieldbus coupler to connect several I/O modules Programmable fieldbus controller to connect several I/O modules
Software	
System software	Linux
Access	Internet Browser, Java V1.6

### Data Transmission

Interfaces	
RS485 bus	up to 6, overvoltage protected
FOC	10/100BaseT, multimode or single mode
I/O modules (depending on device configuration)	Resistor temperature device (RTD), Pt100, Pt1000
	Digital inputs
	Analog inputs
	Relay channels (NO+NC)
	S0
Ethernet	up to 3, overvoltage protected
Data Logger	
Protocol	IP Ethernet, Stem -specific communication
Data rate	10/100 MBit/s
Cable recommended	multimode: HITRONIC® HQN outdoor cable 4G50/125 with SC connector single mode: HITRONIC® HQN outdoor cable 4E9/125 with SC connector

### Electrical Data

Power supply	85 V AC to 264 V AC / 2.5 to 1.2 A AC / 50 Hz to 60 Hz mains
--------------	--

Power consumption	max. 280 W AC; 430 W AC incl. heating
RS485 bus supply	up to four 24 V DC through DC-UPS (buffered DC) one 24 V DC through AC/DC power supply unit (unbuffered DC)
Backup system	24 V DC, 2 batteries AGM 12 V, $\geq 1$ Ah
Overvoltage protection	230 V AC, 24 V DC, RS485 bus, Ethernet
Standards	EN 60950-1, EN 61000-6, UL 62368-1:2014 Ed.2, CSA C22.2#62368-1:2014 Ed.2

## Mechanical Data

	Cabinet	Battery Cabinet
Degree of protection	IP 66	IP 66
Dimensions h x w x d	847 x 636 x 300 mm	647 x 436 x 250 mm
Weight	Approx. 32 kg; dependent on options	Approx. 14 kg; without batteries
Material	UV-resistant, glass-reinforced polyester	UV-resistant, glass-reinforced polyester

## Ambient Conditions

	Cabinet	Battery Cabinet
Operating temperature	-20 °C to +50 °C / -4 °F to +122 °F	-20 °C to 50 °C / -4 °F to 122 °F
Storage temperature	-20 °C to +70 °C / -4 °F to +158 °F	-20 °C to +70 °C / -4 °F to +158 °F
Relative air humidity	up to 95 % non-condensing	up to 95 % non-condensing

## Battery Data

Nominal voltage	12 V
Nominal capacity	$\geq 1$ Ah
Dimensions h x w x d in mm	167.5 x 181.5 x 77
Weight	approx. 6 kg
Terminal	M5
Operating temperature	-15 °C to +40 °C / 5 °F to 104 °F
Storage temperature	-20 °C to +50 °C / -4 °F to 122 °F