

Stem PowerLogger

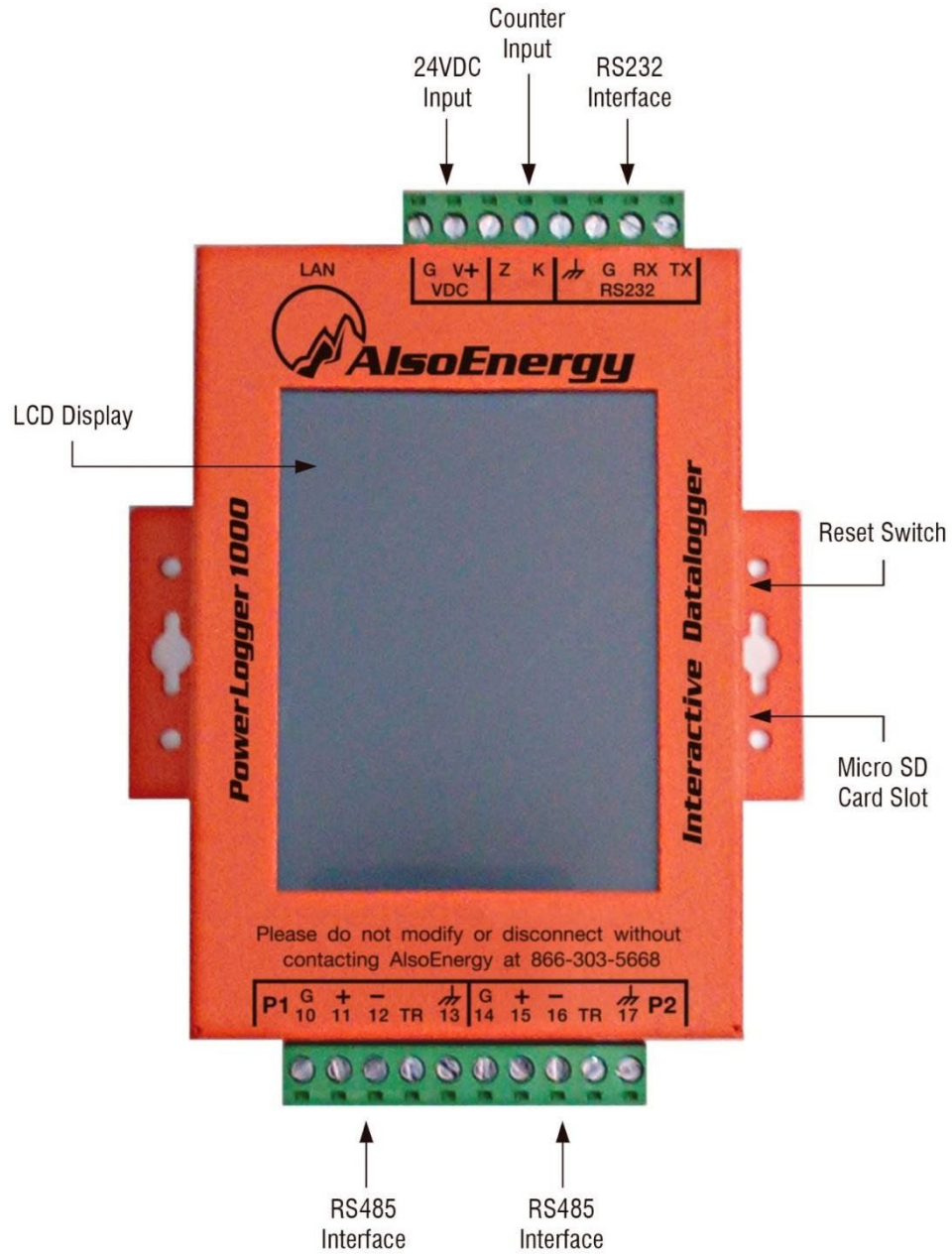

Contents

1. Installation Overview **Error! Bookmark not defined.**

1.1	Setting up PowerLogger .	3
	- Connect 24 VDC power to the top of PowerLogger	3
	- Connect Ethernet cable from local LAN network	3
	- Connect the MODBUS R485 devices to the PowerLogger in port 1 or 2.	3
1.2	Loading screen	3
1.3	Data Logger main screen.	4
1.4	Network Configuration screen	6
1.4.1	Network Testing	6
1.5	Utilities	8
1.5.1	Bus Tools	9
	1.5.1.1 Bus Scan	9
	1.5.1.2 Device Ping Test.	10
	1.5.1.3 Bus Test Raw.	10
	1.5.1.4 Register Watch	11
2.	Power Logger configuration in PT.	10
2.1	Creating the device in PT	10
2.2	Device screen in PT	12
2.2.1	Tabs	12
	2.2.1.1 Configuration.	12
	2.2.1.2 Data.	14
	2.2.1.3 Events	14
	2.2.1.4 Alerts	14
3.	PowerLogger Standard Operation	36
4.	Networking Ports	186
5.	Specifications	186

Installation Overview

1. Mount PowerLogger 1000

1.1. Connect 24 VDC power to the top of PowerLogger 1000.

1.2. Connect Ethernet cable from LAN network.

1.3. Connect the MODBUS RS485 devices to the PowerLogger 1000 in port 1 or 2.

GROUND	10	14
DATA +	11	15
DATA -	12	16
SHIELD	13	17

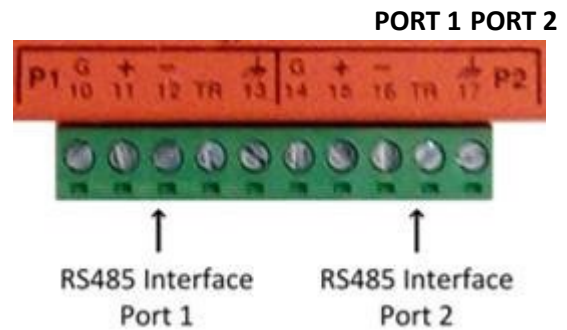

*TR is a 120Ω termination resistor.
 Jump TR to Data- if termination is required.
 There will be two wires on the Data- terminal.

1.4 After all connections are complete turn power on.

2. Loading Screen

On power on the loading screen appears, the logger program will start in 30 seconds.



Local IP address and MAC address are shown.

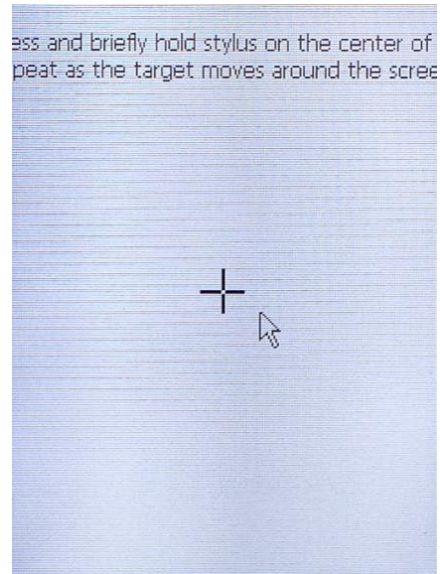

Screen Calibration can be accessed with 3 taps on the loading screen.

3. [PowerLogger 1000 Home Screen](#)

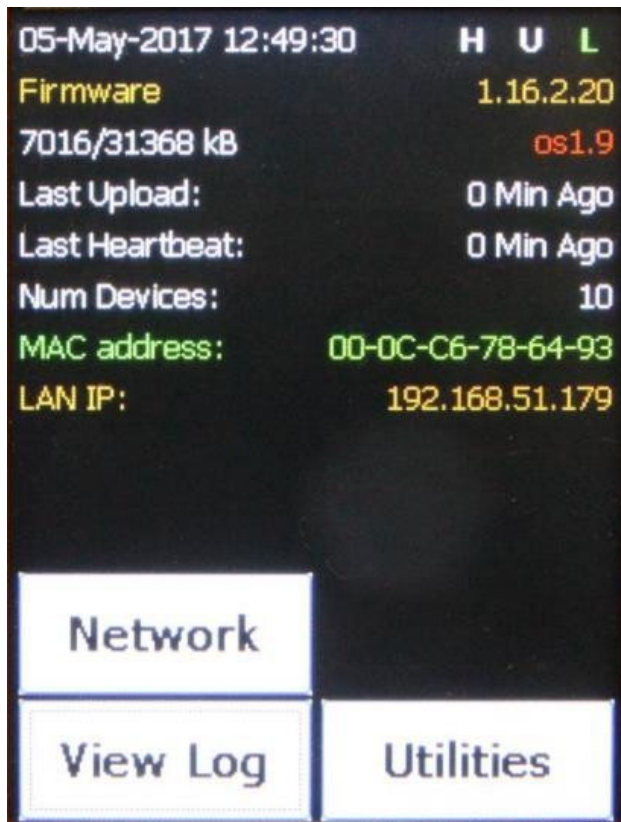

Information shown on this screen:

- **Time/date**
- **H U L:** Heartbeat, Upload, Logging
- **Firmware version (1.16.2.20)**
- **OS version (OS1.9)**
- **Last Upload:** Last time that data has been sent to PowerTrack
- **Last Heartbeat:** Last time that the PowerLogger heartbeat to PowerTrack
- **Num Devices:** Number of devices configured in PowerTrack that are associated to the PowerLogger. (PowerLogger counts as one device.)
- **MAC Address of the LAN port**
- **LAN IP:** Local IP address
- At the bottom of the screen we can see three active buttons: *Network, View Log, Utilities.*

4. Network Configuration Screen

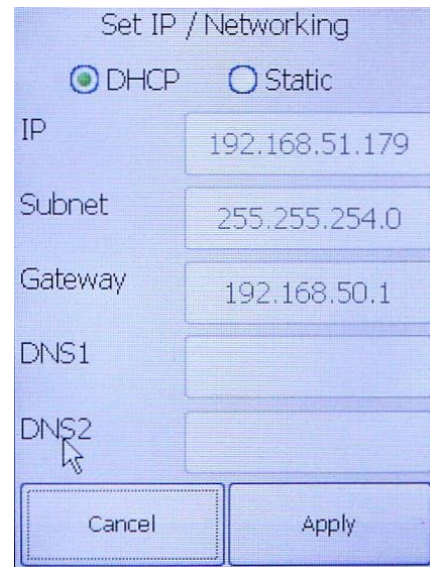
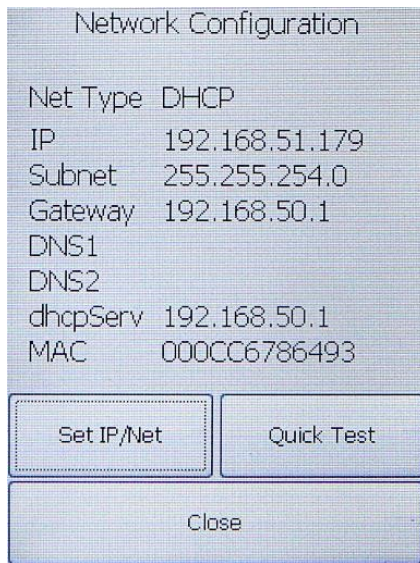

This screen shows information like the IP address, subnet, gateway, MAC address, and Static or DHCP. If any changes in the network configuration need to be made, we can use the "Set IP/Net" option to change IP settings.

Network Testing

Use the "Quick test" button to test the internet connection

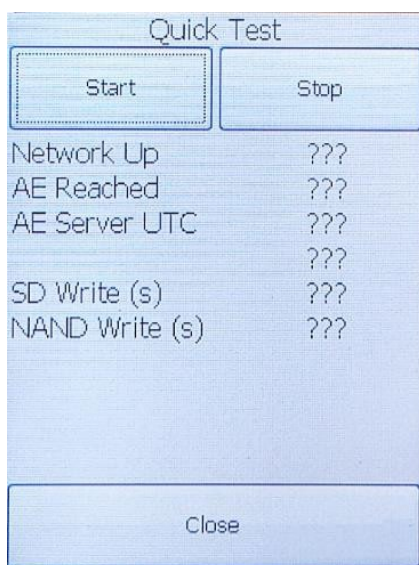

On the Quick Test screen, click Start to begin test.

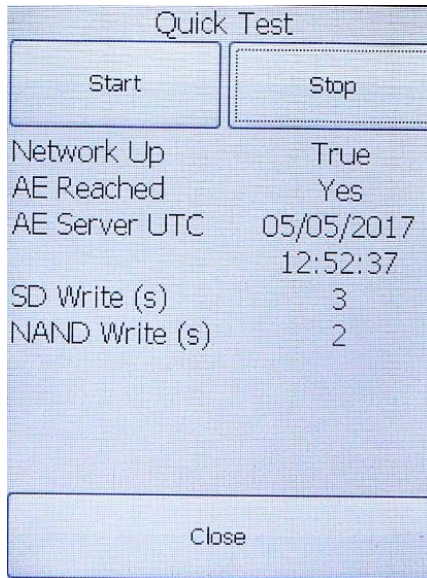

Once we start the test we will automatically see the network status and AE communication status, as well as other information regarding time or SD card and NAND writing function.

This screen shows a successful test.

5. Utilities

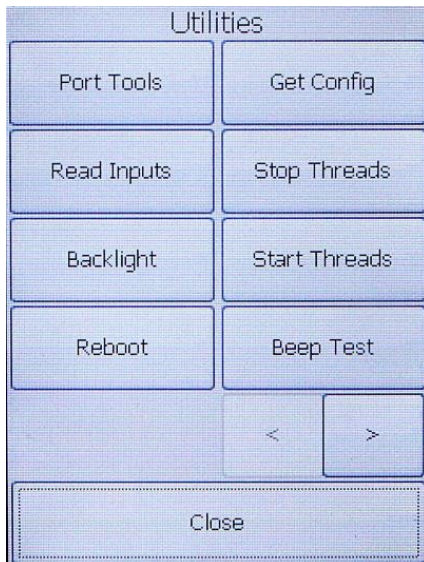

- **Bus Tools:** Device specific testing to scan the port, ping the device, watch registers and test the bus.
- **Get Config:** After changing settings or adding a device in PowerTrack, use Get Config to immediately sync new configuration settings to PowerLogger (to refresh the server cache is required before this step).
- **Read Inputs:** It gives information about some inputs state, as well as board temperature or input voltage
- **Start Threads:** Start all processing
- **Stop Threads:** Stop all processing
- **Backlight:** Allows to change the backlight intensity.
- **Reboot:** It will reboot the PowerLogger
- **Beep Test:** Test the buzzer in the PowerLogger

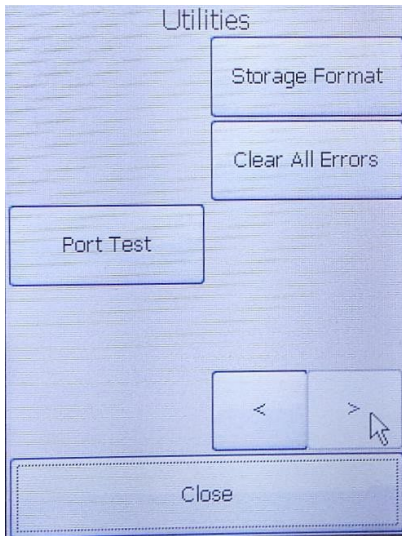

6. Port

- **Storage Format:** Format the SD card
- **Clear All Errors**
- **Port Test**

Tools

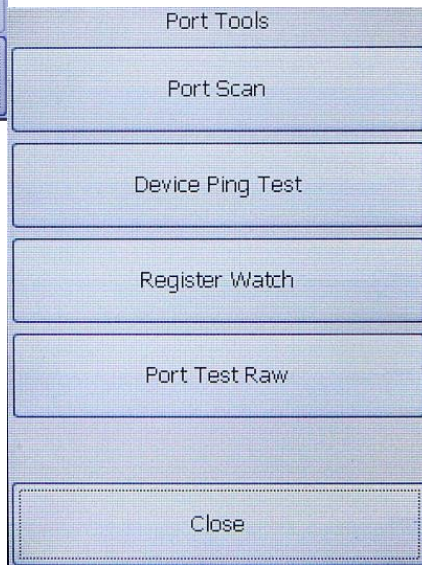

These tools can be used to test devices on the serial ports or the Ethernet network.

6.1. Port Scan

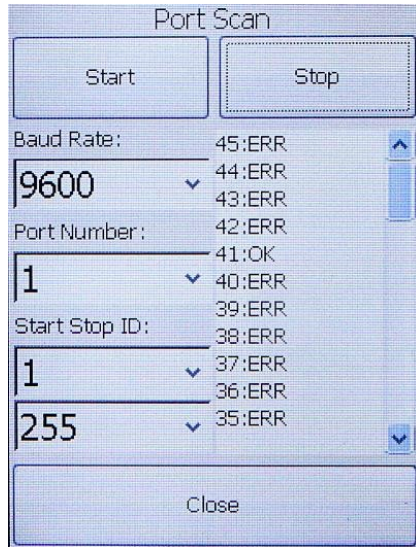

Bus Scan function will scan the bus to see what devices are connected to the PowerLogger.

Select:

- Baud rate
- RS485 port to scan (P1/P2)
- Scan range (1-255).

The window on the right will show the device ID followed by ERR or OK. If it says OK, that means that there is a device with that ID connected to that port.

This utility is useful to find unknown devices on the port. Scanning all valid addresses (1-255) to see how many devices are connected on the RS485 port and what their IDs are.

6.2. Device Ping Test

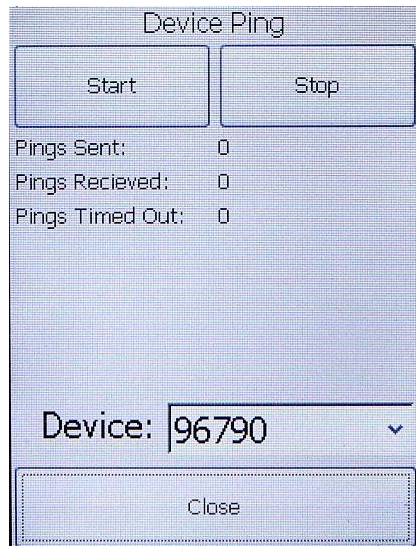

Ping test allow us to ping any device programed to the PowerLogger in PowerTrack. The device number that we can see on the screen matches with the PowerTrack ID number of each device as seen in the upper right of the Hardware section on PowerTrack.

6.3. Bus Test Raw

Bus Test

Start Poll Once Stop

Last Run Last Run Delta

Device: 96790

Close

Bus Test will allow testing of devices already configured for the PowerLogger on the PowerTrack monitoring. Select the device ID and click Start.

6.4. Register Watch

Register Watch Setup

Connection Type:

modbus485

Device Address:

0

Port Name: Stop Bits:

1 2

Baud Rate: Parity:

9600 none

Close Next

Register Watch utility allows polling of register values from any device connected to the PowerLogger, even if it hasn't been created in PowerTrack. These devices can be connected via Modbus RTU or Modbus TCP.

On the first screen select device settings:

- if the connection is RTU or TCP
- RS485 port 1 or 2
- baud rate setting
- parity setting
- the address of the device

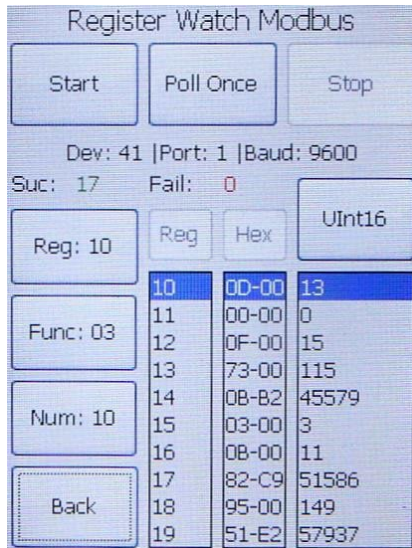

The second screen will show the value of the registers we are polling. To do this, we need to:

- select the starting number of the registers to poll (Reg: register#)
- select if this register is an input register, holding register, etc... (Func: 01,02,03,04)
- select how many registers to poll (10 as default)
- select the data type (UInt16, float, ...) by clicking at the button showed as UInt16 in the picture.

Once everything is configured click Start and the PowerLogger 1000 will start polling data. The PowerLogger will poll register data 50 times before it stops. To keep polling data, click Start again. To poll just once click the "Poll Once" button.

2. PowerLogger configuration in PowerTrack

2.1 Creating the device in PT

To create a new device in PowerTrack, we must search for the site we want to create it in. Once we are in that site, we are going to click *Hardware*, under *Maintenance* box.



Once we click *Hardware*, we should be able to see the hardware screen on the right side of the screen. To

be able to add a new device we must click the  button on the upper right corner on the screen.

The *Add Hardware* window will pop up:

A screenshot of a dialog box titled 'Add hardware'. It contains the following fields and controls:

- Description: Text box containing 'PowerLogger 12345'
- Data logger / gateway: Dropdown menu (empty)
- Data logger / gateway ID: Text box containing '000CC678XXXXX'
- Data logger / gateway type: Dropdown menu containing 'AE_Maki'
- Hardware type: Dropdown menu containing 'Gateway'
- Device: Text 'Done (2)' followed by a dropdown menu containing 'Maki Gateway'
- Quantity: Text box containing '1'
- DECK Device
- OK and Cancel buttons at the bottom.

- Description: Brief description of the device to differentiate it from the other devices.

- Data logger / gateway ID: Type MAC address of the device.

- Data logger / gateway type: *AE_Maki* should be selected

- Hardware type: *Gateway* should be selected

- Device: PowerLogger Gateway

Click OK.

2.2 Device Screen in PT

PowerLogger 12345
PowerTrack™ : Also Energy : Tested RMAs
PowerLogger 12345 Bulk setup

Hardware
Hardware added (1 of 1) 96120
InvalidData

Configuration

Description: PowerLogger 12345 Install date: 4/10/2017 Enable Validated
Asset ID: Type: Gateway No log Offline
 Debug Report exclude
Instance: 2 FID: GW2 Sort: 0 Driver: Maki Gateway Limited communication
Gateway ID: 000CC678XXXXX Port: 0 Address: 0 Serial:
Serial number: Baud:
Model number: Site: Tested RMAs

Configuration

Type: Commercial IP Address: Gateway IP:
Connection: DHCP Mask: DNS 1:
DNS 2:

Status

Client firmware:

Server firmware: maki.exe;1.16.2.1
 Update Debug
Last heartbeat: IP 1: IP 2:
Last reboot:

Params

2.2.1 Tabs

Once we have created the device we will be able to see the *Device Screen*. On the left side of this screen we can find the following tabs:

2.2.1.1 Configuration

In the configuration tab, we can see general information about the device. We are going to divide this section in 3 different sections to ease the reader understanding of the document.

- In the upper section of the screen we can see the information we added when creating the device like Description, Install date, Driver, Gateway ID, ...

There are some options that we can select like Enabling the device or not, Debug mode, Offline, ...

Description: PowerLogger 12345 Install date: 4/10/2017 Enable Validated
Asset ID: Type: Gateway No log Offline
 Debug Report exclude
Instance: 2 FID: GW2 Sort: 0 Driver: Maki Gateway Limited communication
Gateway ID: 000CC678XXXXX Port: 0 Address: 0 Serial:
Serial number: Baud:
Model number: Site: Tested RMAs

- The middle section of the screen is used to note network settings on the device (this information is merely used by the user as a reminder, not strictly necessary).

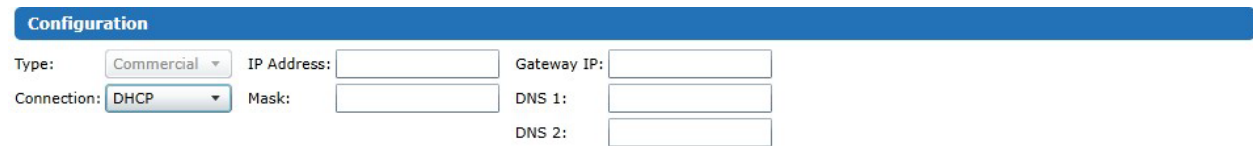

- In the lower section of the screen we can see the device firmware information, we can select default firmware and parameters to be installed in the device and we can send some commands.

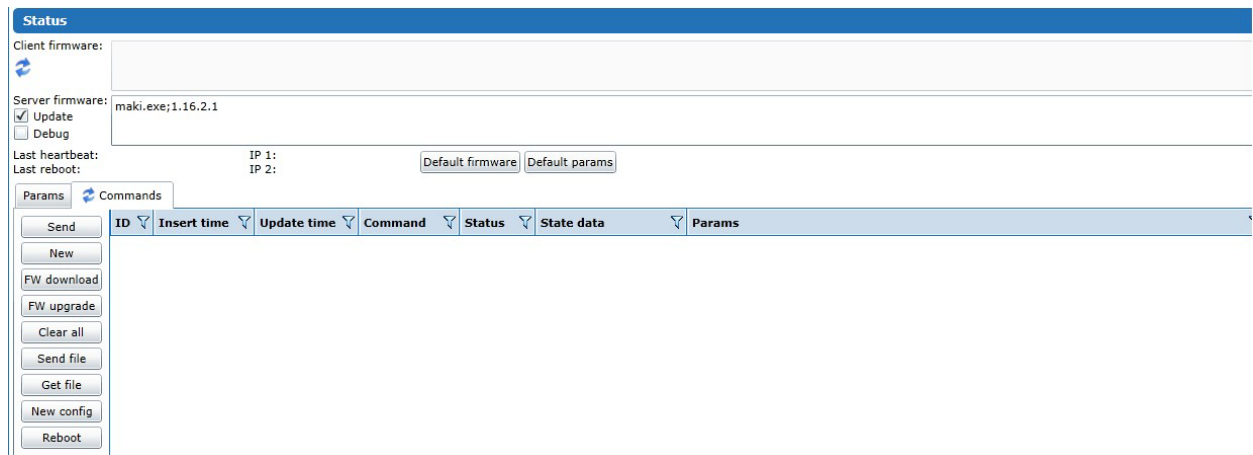

To install **the latest firmware and parameters** in the device we must follow the following steps:

- Click *Default firmware*
- Click *Default params*
- Uncheck and re-check the *Update check box*
- Wait for around 20 min without changing anything.
- Check that the client firmware matches the server firmware.

Some commands can be sent to

2.2.1.2 Data

Data tab will allow us to see some information about the device itself, such as total memory capacity, OS version, FW version, internal time, ...

Configuration		Last updated: 4/11/2017 11:12:57 AM		Last good data:4/11/2017 11:12:41 AM		<input type="checkbox"/> Show register detail	
Device							
Offsets	Resources						
Data	Name	Value	Units	Update			
Detail	DL time	20170411T171241					
Events	DL time UTC	20170411T171241					
Alerts	Mem Q Count	0					
SCADA	Model Name	Maki					
Settings	OS Version	os1.6					
Tags	Firmware Build	1.16.2.1					
Server	Free MB To Caller	1908.56	MB				
Archive	Total Capacity MB	1908.69	MB				
Reference	Total Free MB	1908.56	MB				
Access Control	Mem Q Count	0					
Notes	Maki Password	3i7t98					

2.2.1.3 Events

The events tab is going to allow us to receive notifications of any event or alert that occurs in the device.

We can subscribe simply clicking the *Subscribe* button at the upper right corner of the screen.

2.2.1.4 Alerts

In the alert tab, we will be able to see the alerts that have been created for this device. We will be able to set some parameters like the trigger alert or active time. At the same time, if we don't want to subscribe to all the events in the events tab, we can subscribe to only the alerts we are interested in. To do this we can click the *Subscribe* button in each one.

Configuration PowerLogger 12345 Alerts

Enable	ID	Alert	Name	Description	Help
<input checked="" type="checkbox"/>	0	253	Gateway heartbeat	Detects missing communication from a data logger or gateway.	

Gateway heartbeat

Active time Level: Site production impact: %
 Sun position Delays (hours): Trigger: Resolve:
 Don't trigger when snow is present.

You are not currently subscribed to events occurring on or below this Gateway heartbeat node. [Subscribe](#)

[Subscribe external email...](#)

2.2.1.5 Settings

The settings window will allow us to add some settings to the device. Normally all we need is the uploading rate (200 by default).

Configuration All

Name	Type	Source	Value
dev:rate	String		200

2.2.1.6 Other tabs

The other tabs *SCADA*, *Tags*, *Server*, *Archive* and *Notes* are not important for configuration purposes.

3. PowerLogger Standard Operation

The AEGWL gathers data from devices and sends the data over the internet to a hosted database:

1. The AEGWL powers up

2. The AEGWL gets its IP address via either DHCP or its static assigned network configuration. Contact Stem™ for the correct documentation for configuring your AEGWL environment.
3. The AEGWL resolves www.Stem.com via DNS services.
4. The AEGWL periodically updates its real time clock using network time services.
5. The AEGWL contacts AE Web Services (AEWS) supplying its MAC address and current code version.
6. The AEWS responds as:
 - 6.1. Your code is not correct. Update your program with the code that follows then reboot.
 - 6.2. Your code is correct. Configuration data follows.
7. The AEGWL uses the configuration data to query devices connected to it.
8. The AEGWL packetizes the received device data and sends it to the AEWS via https.
9. The AEGWL sleeps for the configured length of time.
10. The AEGWL wakes up and repeats the process at step 3.

4. Networking Ports

The AEGWL is designed to exist in a DHCP or static IP environment behind a firewall. It does not need an external internet IP address or ports forwarded. This table shows the unique ports opened.

	Inbound Ports	Outbound Ports
HTTP: Port 80 (TCP)	☐	☐
HTTPS: Port (443) TCP		☐
SNTP: Port 123 (UDP)		☐
SMTP Port 25 (TCP)		☐
FTP: Port 20 & 21 (TCP)	Only if local diagnostic PC present	
Telnet: Port 23 (TCP)	Only if local diagnostic PC present	

5. Specifications

The PowerLogger incorporates a 2 RS-485 interface, a RS-232 interface, a counter input, a color quarter VGA touchscreen for human interface and a 10/100 auto-switch Ethernet interface. Long term operation is controlled by the PowerTrack monitoring platform.

Input Voltage: 9-42 VDC

Power Consumption: < 1.7W

Operating Environment: -40 to 85°C (-40 to 185°F), 10 – 90% relative humidity non-condensing

Storage Temperature: -40 to 85°C (-40 to 185°F)

Chassis: DIN rail mountable metal 3" tall by 2" wide by 1" deep

6. Troubleshooting

- PowerLogger doesn't power up:

- Check that the voltage applied to the PowerLogger is 24V.
- Check that power cables are properly connected.

- PowerLogger powers up, logger beeps three times after 30 seconds, but LCD display is black:

- The LCD is bad, request RMA.

- PowerLogger is not reporting in PowerTrack:

- Check that the PowerLogger network is configured properly (this can be checked on the network screen in the UI).
- Check site network or cell modem.
- Check that the PowerLogger configuration in PowerTrack is valid.

- Devices connected to PowerLogger are not reporting in PowerTrack:

- Refresh the cache using the following link:
[http://www.alsoenergy.com/aeservlet/scache.man?cmd=cleargateway&gid="PL1000 MAC address"](http://www.alsoenergy.com/aeservlet/scache.man?cmd=cleargateway&gid=). After that, get config using the UI or PowerTrack command.
- Check that the Power Logger's network is configured properly.
- Check site network or cell modem.
- Check that the devices have been configured properly in PowerTrack (devices IDs, baud rates, modbus ports, ...) .

- Port Scan doesn't detect any device:

- Check that the physical modbus connection is correct.
- Check that Baud rate, RS485 port (P1/P2) and scan range are right on the UI

- Register Watch Modbus fails:

Check that the register watch settings are right on the UI:

- if the connection is RTU or TCP
- RS485 port 1 or 2
- baud rate setting
- parity setting
- the address of the device
- Select the right register function value
- Select a valid register range

Check that the physical modbus connection is correct.

- IP address on main screen shows 0.0.0.0:

- Network is not detected
- Go to Network configuration screen
- Check that network configuration is right (DHCP or static)
- Reboot the device
- If the problem still exists, check site network or cell modem

- Bad clock ERR on main screen:

- This error usually happens when there is a network issue so the unit cannot grab the date/time from the internet. Most of the times it can be fixed rebooting the unit. If that doesn't work, check network connection.

- Touchscreen is not calibrated:

- Power cycle the device.
- Screen calibration can be accessed with 3 taps on the loading screen.