



stem

PLCS 600 INSTALLATION GUIDE

October 2025

Revision 5

Unlock Energy Intelligence

Table of Contents

Contents

| | |
|--|----|
| Table of Contents | 2 |
| WARNING | 3 |
| AVERTISSEMENT | 3 |
| Limitation of Liability | 5 |
| FCC Statement | 6 |
| Hardware Overview | 7 |
| Mounting the Enclosure | 8 |
| Location | 8 |
| Distance Limitations | 8 |
| Enclosure Penetrations | 8 |
| Wiring to External Connections | 10 |
| Control Power | 10 |
| Revenue Grade Meter | 10 |
| Current Transformer and Voltage Reference Installation | 12 |
| Weather Sensor Installation | 16 |
| Reference Cell and Temperature Sensor Mounting | 16 |
| Weather Sensor Wiring | 18 |
| Modbus Communication Wiring | 19 |
| RS485 for Modbus RTU Communication | 19 |
| CAT5e Ethernet for Modbus TCP Communication | 21 |
| AlsoEnergy Modbus Address Standard | 21 |
| Connecting to the Internet | 23 |

Installation Personnel

Installation and maintenance of the communications enclosure should only be performed by qualified, competent personnel who have appropriate training and experience with high voltage and current devices. The communications enclosure must be installed in accordance with all Local and National Electrical Safety Codes.

WARNING

Failure to observe the following may result in severe injury or death:

- Keep these instructions.
- There are no user serviceable parts inside. Refer service to an authorized service person.
- During normal operation of this device, hazardous voltages are present on the input terminals of the devices and throughout the connected power lines. With their primary circuit energized, current transformers (CTs) may generate high voltage when their secondary windings are open. Follow standard safety precautions while performing any installation or service work (i.e. remove line/ PT fuses, short CT secondaries, etc.).
- This product must be used in accordance with the instructions in this manual, otherwise the product may not perform as expected or cause hazards to the user.

AVERTISSEMENT

Le manque d'observer le suivant peut avoir comme conséquence des dommages ou la mort graves:

- Il n'y a aucune pièce utile d'utilisateur à l'intérieur, se réfèrent le service à une personne autorisée de service.
- Pendant le fonctionnement normal de ce dispositif, les tensions dangereuses sont présentes sur les bandes terminales d'entrée du dispositif et dans toutes les lignes

électriques reliées. Leur circuit primaire étant activé, les transformateurs de courant (CTs) peuvent produire de la tension quand leurs enroulements secondaires sont ouverts. Suivez les mesures de sécurité standard tout en effectuant n'importe quelle installation ou travail de service (c.-à-d. enlevez la ligne fusibles de pinte, secondaires courts de CT, etc.).

- Gardez ces instructions.
- Ce produit doit être employé selon les instructions en ce manuel, autrement le produit peut exécuter comme prévu ou ne pas causer des risques à l'utilisateur.

Danger

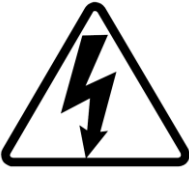

Line voltages up to 600 VRMS are present on the input terminals of the device and throughout the connected line circuits during normal operation. These voltages may cause severe injury or death. Installation and servicing should be performed only by qualified, properly trained personnel. This is a Class III measurement device.

Danger

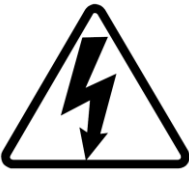

Tensions secteur jusqu'à 600 VRMS sont présent sur les bornes d'entrée du dispositif et dans toute la ligne reliée circuits pendant l'opération normale. Ces tensions peuvent causer des dommages ou la mort graves. L'installation et l'entretien devraient être assurés seulement par le personnel qualifié et correctement qualifié. C'est un dispositif de mesure de la classe III.

Limitation of Liability

AlsoEnergy™ Inc. ("AE") reserves the right to make changes to its products and/or their specifications without notice. Obtain the latest version of the device specifications to assure the most current information is available to the customer.

AE assumes no liability for applications assistance, customer's system design, or infringement of patents or copyrights of third parties by/or arising from the use of AE's devices.

AE SHALL NOT BE LIABLE FOR CONSEQUENTIAL DAMAGES SUSTAINED IN CONNECTION WITH AE PRODUCTS, EXCEPT TO THE EXTENT PROHIBITED BY APPLICABLE LAW. FURTHERMORE, AE NEITHER ALLOWS NOR AUTHORIZES ANY OTHER PERSON TO ASSUME FOR IT ANY SUCH OBLIGATION OR LIABILITY.

Although the information contained in this document is believed to be accurate, AE assumes no CSA - C22 Statement.

This product meets the requirements of Can/CSA-C22.2 no. 61010-1, third edition, including Amendment 1, or a later version of the same standard incorporating the same level of testing requirements.



FCC Statement

This device is classified as a Class A digital device.

This device complies with Part 15 of the FCC Rules. Operation is subject to the following two conditions: (1) This device may not cause harmful interference, and (2) this device must accept any interference received, including interference that may cause undesired operations.

Hardware Overview

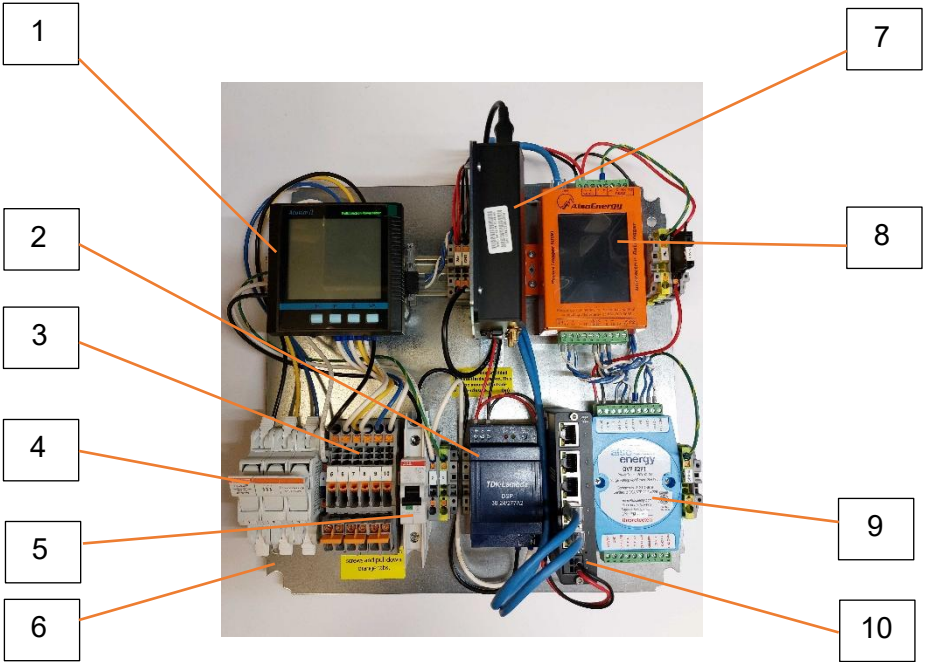

| | |
|----|--|
| 1 | Revenue Grade Meter |
| 2 | DC Power Supply |
| 3 | Current Transformer Terminal Blocks |
| 4 | Voltage Reference Fused Disconnect |
| 5 | Control Power Input Terminals and Breaker |
| 6 | Grounding Stud |
| 7 | Cellular Modem |
| 8 | Data Logger |
| 9 | RS485 and 24 VDC Surge Suppressor for External Device Connection |
| 10 | 5-port Ethernet Switch |

Mounting the Enclosure

Location

- The unit should be placed in a secure location, away from any potential tampering.
- Mount to an indoor or outdoor wall using four M8 or 5/16" bolts through the holes in the mounting flanges.

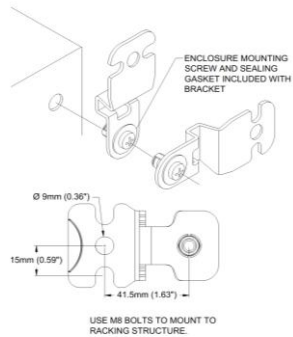
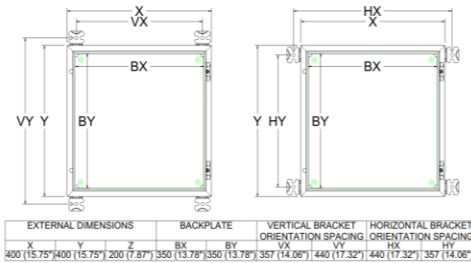

- Allow space beneath the enclosure for conduit runs for all input and output wires.
- Allow sufficient working space in front of and beside the unit to allow the front door to open fully.

Distance Limitations

- Maximum 100m (328 feet) from an internet connected network port if not using an internal cellular modem.
- No further than 2m (6 feet) from earth ground.
- Maximum 1200m (4,000 feet) between communications enclosure and last RS-485 device

Enclosure Penetrations

- All conduits and wires must enter from the bottom of the enclosure. Do not penetrate the top or sides of the enclosure.
- All entry points must be sealed using weatherproof connectors.

- Warranty will be voided if there are entry points on the top or sides of the enclosure.
- All penetrations must be liquid tight. Use outdoor rated conduit connections for all outdoor installation.
- AlsoEnergy provides a desiccant packet within all enclosures to reduce the internal humidity of the enclosure. Replace the desiccant packet when the humidity indicator card shows 40% relative humidity or higher.
- AC power, voltage reference, and current transformer wire must not be run through conduit carrying RS485, CAT5e, or analog sensor wires. Penetrate the enclosure for the two separate conduits as shown.

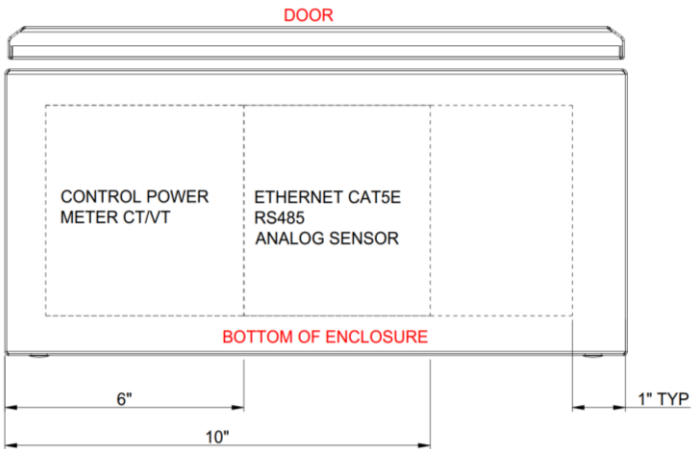

Wiring to External Connections

Control Power

- The power supply in the AlsoEnergy PLCS 600 requires 100-277VAC at 0.2A-0.4A, 50-60 Hz, and is auto-ranging. A neutral wire is required for power, do not use two “hot” phases to power the enclosure.
- The monitoring system should be protected by a main circuit breaker rated up to 20 amps.
- Power may be provided from a dedicated circuit. Providing power from the line side of the voltage reference is not permitted in all areas. Consult NEC and local regulations if not powering the enclosure from a dedicated breaker.

Check that power is off at the main breaker and that the breaker inside the PLCS 600 is off before starting any work. Complete all other enclosure connections before energizing the enclosure.

Connect the AC input power with 12-14AWG as follows:

- (1) Circuit Breaker - AC line 100-277VAC (black)
- (2) Terminal Block – AC neutral (white)
- (3) Green/Yellow Terminal Block – EGC (green, green/yellow, or bare copper)



Revenue Grade Meter

Install Current Transformers (CTs) and make all connections with all system AC and DC power turned **OFF**. If you have any questions, please call AlsoEnergy technical support before turning power on.

Danger

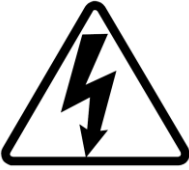

This is a Class III Measurement Device. Line voltages up to 600 VRMS are present on the input terminals of the device and throughout the connected line circuits during normal operation. These voltages may cause severe injury or death. Installation and servicing should be performed only by qualified, properly trained personnel.

Current Transformer and Voltage Reference Installation

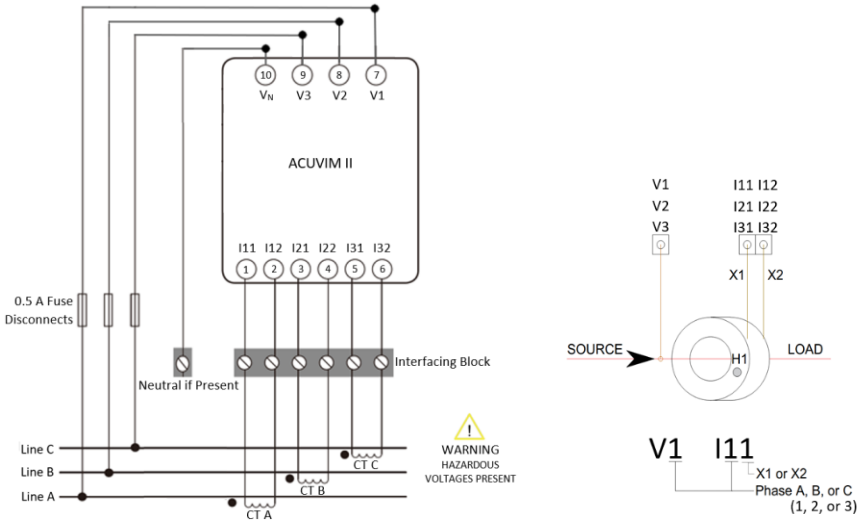

- Place the CT around one phase of the solar generation output so that dot or "H1" mark faces the inverter(s).
- Voltage reference and CT location should be in the same vicinity and must not be separated by a transformer.
- CT and VT are phase-specific and must be matched when connecting to the meter. the voltage tap "V1" must connect to the same phase that is being measured by the CT connected to "I11" and "I12". Similarly, "V2" is associated with "I21" and "I22" and "V3" with "I31" and "I33".
- Observe correct polarity of the CT leads. X1 and X2 will be labeled or color coded by the CT manufacturer.

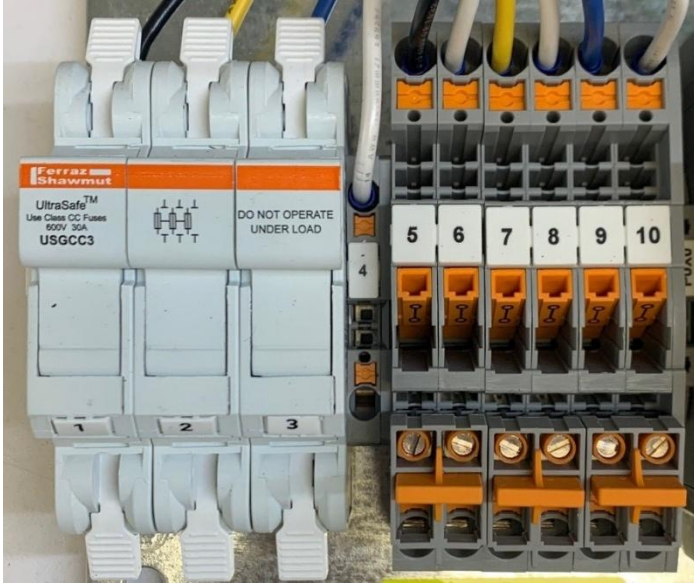

| Terminal ID | Wire |
|-------------|---------------------------|
| 1 | Voltage Phase A (V1) |
| 2 | Voltage Phase B (V2) |
| 3 | Voltage Phase C (V3) |
| 4 | Neutral (V _N) |
| 5 | CT X1 Phase A (I11) |
| 6 | CT X2 Phase A (I12) |
| 7 | CT X1 Phase B (I21) |
| 8 | CT X2 Phase B (I22) |
| 9 | CT X1 Phase C (I31) |
| 10 | CT X1 Phase C (I32) |

- To replace fuses or de-energize the meter voltage reference pull down on the fuse holder. Replace fuses with 0.5A 600V Class CC fuses.

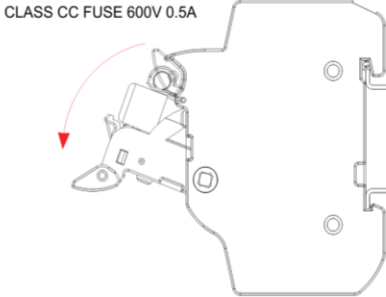

- CT shorting pins are used to de-energize CT leads into the meter. PLCS enclosures are shipped with pins in the shorted position for installation. After CT leads have been connected the pins must be released for proper meter operation.

IMPORTANT

CTs are energized and potentially hazardous even if shorting pins are engaged. Always de-energize measured feeders before installing or disconnecting CTs.

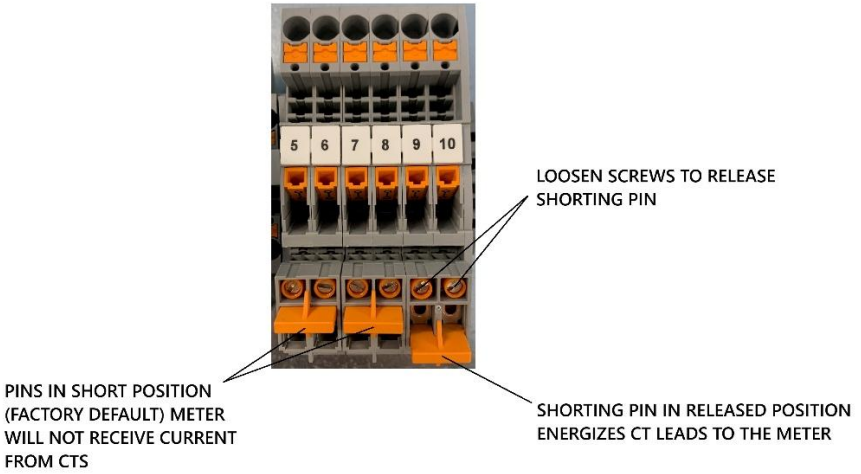

Weather Sensor Installation

IMPORTANT - DO NOT CUT, SPLICE, OR SHORTEN THE LEAD FOR ANALOG BACK OF MODULE TEMPERATURE OR WIND SPEED SENSORS.

The sensor is calibrated, and the included cable is pre-terminated for direct connection to the reference cell. The reference cell must be mounted near the monitored module. Excess cable should be wrapped and secured to the rack structure with zip ties.

Reference Cell and Temperature Sensor Mounting

- Mount the reference cell directly to the module frame at the perimeter of the array.
- The reference cell can accommodate two auxiliary temperatures (ambient and/or module) and one wind speed sensor. Only one wind and ambient temp sensor can be used. Ambient must be installed on RTD1. Module temp can be installed on both RTD 1 and 2.
- If applicable, connect the back of module temperature, ambient temperature and wind speed sensor cables to the appropriate ports on the Atonometrics reference cell and screw the water-tight connector firmly into place.
- The reference cell ships with a 4m cable for power and RS485 data. The cable may be extended following RS485 daisy chain configuration best practices. All splices must be made inside a weather-tight enclosure or using liquid-tight connectors.
- Connect the pigtailed wires to the PLCS 600 enclosure to the bottom of the 24VDC and RS485 surge suppressor.
- The back of module temperature sensor should be affixed to the center of the back of the module away from the edge of the array.

- The ambient temperature sensor should be mounted outdoors in a north-facing, always-shaded location with the sensor pointing down.

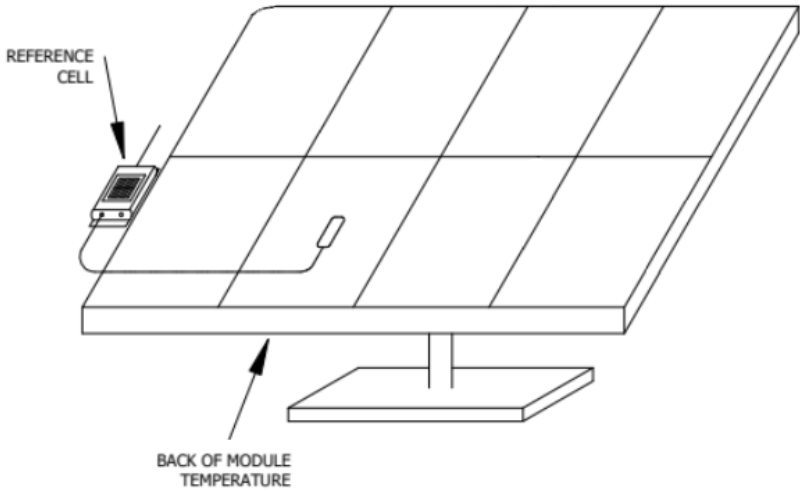

| Atonometrics RS485 and 24VDC Connections | | |
|--|-----------------------|-------------------|
| Wire Color | Signal | PLCS 600 Terminal |
| Brown | Supply Power Positive | +24VDC |
| Black | Supply Power Negative | GND |
| Grey | RS485 Data + | CH2 D+ |
| White | RS485 Data - | CH2 D- |
| Black (Thick) | Shield | Shield/PE |

Weather Sensor Wiring

Each OVP-R2P1 unit provides surge protection for two RS485 buses and one 24 VDC bus.

- Field wiring must connect at the unprotected side of the board to channel 2 of the OVP.
- One or both shield/PE terminals must be connected to earth ground for proper operation of the surge suppressor.

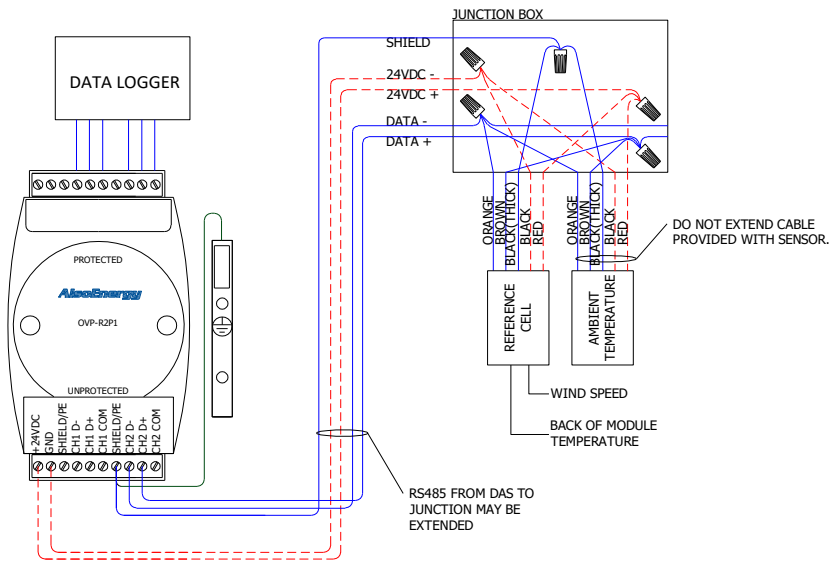

Modbus Communication Wiring

RS485 for Modbus RTU Communication

- Use Belden 3106A or equivalent shielded, twisted pair RS485 wire.
- RS485 must be wired in a single “daisy chain” configuration.
- If a termination resistor is to be used it must be only on the last device in the chain.
- The PLCS 600 supports a maximum of 20 inverters.
- Avoid ground loops by landing the shield drain only at the PLCS 600 enclosure. Never ground the shield in more than one location.
- The total RS485 daisy chain should not exceed 4000' (1219m) in wire length.
- RS485 connections are commonly labeled as ‘A’ or ‘B’ but the convention is not standardized. The polarity of the inverter daisy chain must match the datalogger, wire according to data+ and data- as opposed to A and B. Refer to inverter manufacturer documentation if the polarity of the RS485 terminations is not clear. Set device Modbus addresses per the [AlsoEnergy Modbus Address Standard](#).

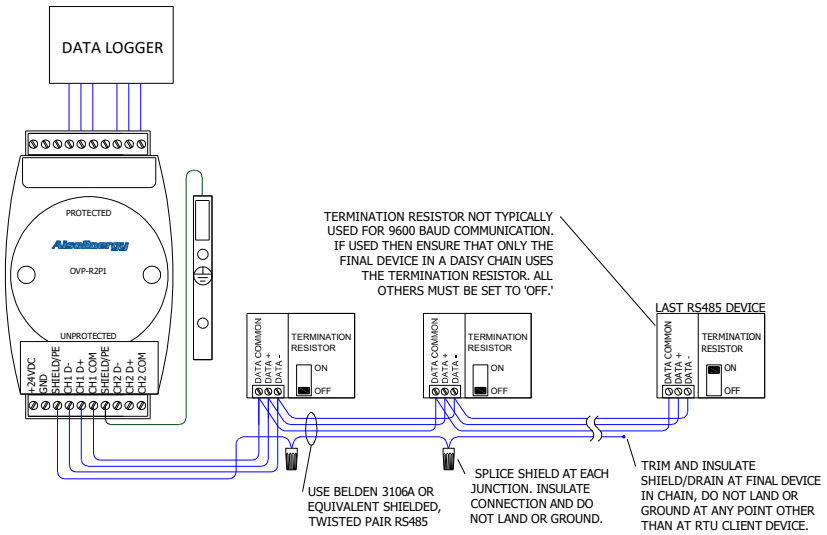

Correct RS485 daisy chain configuration must be followed, avoid star or branch configurations. S tubs should be kept as possible never exceeding 50' (15m).

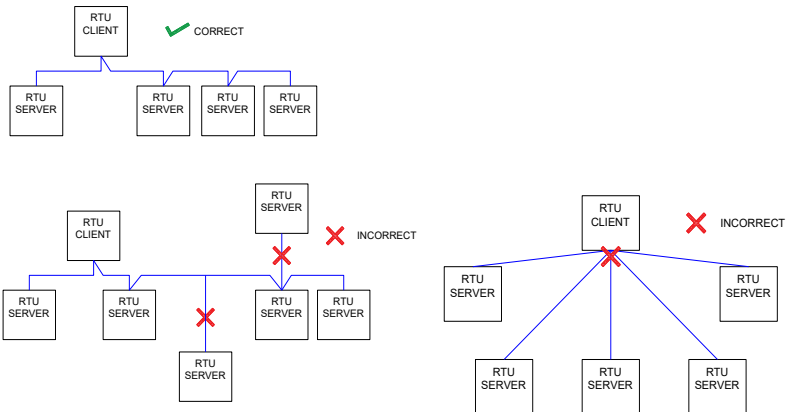

CAT5e Ethernet for Modbus TCP Communication

- Use Belden 7919A or equivalent shielded CAT5e cable for all ethernet connections.
- Snap the RJ45 connectors into the PLCS 600 network switch and the inverter communication module.
- Each device must be assigned a static IP address on the network. If the PLCS 600 was purchased with the modem configure devices with the following gateway and subnet mask, configure IP address per the [AlsoEnergy Modbus Address Standard](#).

| | |
|-----------------|---------------|
| Default Gateway | 192.168.13.1 |
| Subnet Mask | 255.255.255.0 |

If using an existing network, you must obtain network configuration and one static IP address for each Modbus TCP connected device from the network administrator.

AlsoEnergy Modbus Address Standard

Each device must be configured with a unique Modbus ID or IP address.

- For all devices using Modbus RTU (RS485) communication protocol, configure the device ID per the table below using the first number in the range for each device and incrementing.
 - Example:
 - Production Meter 1 – Address 41
 - Production Meter 2 – Address 42
 - Consumption Meter – Address 43

- Configure the rs485 bus for 9600 Baud Rate, 8 data bits, No Parity, and 1 stop bit (9600 8N1).
- For all devices using Modbus TCP (ethernet) communication with an AlsoEnergy modem provided, configure the IP address per the table below using the first number in the range for each device and incrementing.
 - Example:
 - Inverter 1 – IP Address 192.168.13.51
 - Inverter 2 – IP Address 192.168.13.52
 - Inverter 15 – IP Address 192.168.13.65

| AlsoEnergy Modbus Address Standard | | |
|--|----------------------|---|
| Device Type | Modbus RTU Device ID | IP Address (PLCS-600-CM-XX models only) |
| Reference Cell | 6 - 10 | N/A |
| Module or Ambient Temperature | 11 - 15 | N/A |
| Miscellaneous Weather Sensors | 16 - 20 | N/A |
| Pyranometers | 21 - 25 | N/A |
| Meters | 41-50 | 192.168.13.41 - 192.168.13.50 |
| Inverters | 1 - 20* | 192.168.13.51 – 192.168.13.100 |
| Inverter Gateways (SMA Datamanager M, Sungrow Logger 3000, etc.) | N/A | 192.168.13.161 – 192.168.13.162 |
| Tracker Devices | 171 - 180 | 192.168.13.171 – 192.168.13.180 |
| Relay, Recloser, Switchgear | 181 – 190 | 192.168.13.181 – 192.169.13.190 |

*RS485 daisy chain for inverters using Modbus RTU (RS485) communication protocol must not include weather sensors, meters, or other devices. Connect inverter RS485 daisy chain to PLCS600 channel 1 and all other devices to channel 2.

Connecting to the Internet

The PLCS 600 is provided with a cellular modem for internet access. The modem can be removed from the backplate by removing the two hex screws securing the bracket to the backplate. Reinstall the modem after all connections are complete.

- Route the antenna wires through the penetration on the bottom of the enclosure and mount the antenna. For best signal strength mount the antenna as high as possible and away from large magnetic fields.
- Connect the antenna to the coaxial terminals on the top of the modem.
 - LTE-1 to MAIN and LTE-2 to DIV
- Connect the modem to the ethernet switch in the enclosure using the included CAT6 patch cable.
- Connect the power cable and ensure that it clicks into place.